

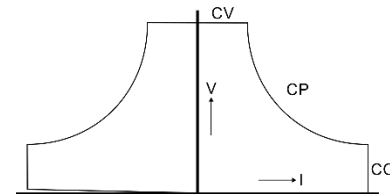

SM15K - Series 15kW DC POWER SUPPLIES

Bi-Directional - Constant Power

Models	Voltage range	Current range
SM70-CP-450	0 – 70 V	-450 – 450 A
SM210-CP-150	0 – 210 V	-150 – 150 A
SM500-CP-90	0 – 500 V	-90 – 90 A
SM1000-CP-45	0 – 1000 V	-45 – 45 A
SM1500-CP-30	0 – 1500 V	-30 – 30 A



Features

- 15 kW bidirectional DC source & sink
- Constant-power output curve for extended operating range
- Regenerative design: sink power returned to the grid
- $\geq 95\%$ efficiency resulting in low heat dissipation
- Fast digital control with tunable load response
- Rated for continuous full-power operation
- Comprehensive overload and short-circuit protection

Functionalities

- Wide-range three-phase AC input
- Expandable in functions, interfaces and Master-Slave
- Built-in Ethernet interface with browser-based web interface
- Digital encoders for voltage/current setting and navigation
- Large front-panel display with menu-driven operation
- Temperature-controlled fans for low audible noise
- EMC performance beyond CE (low emission, high immunity)

	SM70-CP-450	SM210-CP-150	SM500-CP-90	SM1000-CP-45	SM1500-CP-30
Output rating Voltage range Current range	0 - 70 V -450 - 450 A	0 - 210 V -150 - 150 A	0 - 500 V -90 - 90 A	0 - 1000 V -45 - 45 A	0 - 1500 V -30 - 30 A
Regenerative mode Minimum sink voltage <i>Note: Unit switches automatically between source ↔ sink.</i> Absolute maximum sink voltage Minimum sink current	1.2 V @ -450 A 0.8 V @ -215 A 0.8 V @ -45 A 74 V 0.4%	3.0 V @ -150 A 1.5 V @ -75 A 1.5 V @ -15 A 220 V 0.4%	7.0 V @ -90 A 5.0 V @ -30 A 2.0 V @ -10 A 525 V 0.4%	12.0 V @ -45 A 8.5 V @ -15 A 2.5 V @ -5 A 1050 V 0.4%	19.5 V @ -30 A 14 V @ -10 A 4.5 V @ -3 A 1575 V 0.4%
AC Input Rated voltage range Rated frequency Rated current Current, 15kW Power factor, 15kW / 7.5kW Internal fuses Standby input power ($V_o=I_o=0$) ¹ Standby input power ($V_o=V_{max}$) ¹	380 - 480 V 50 / 60 Hz Maximum 27 A 23 A 0.996 / 0.988 30 AT 100 W 180 W				
Efficiency (Sink & Source mode): 15 kW, $I_{out}=100\%$ 15 kW, $U_{out}=100\%$	95 % 96 %				
Regulation Load 0 - 100% CV Line 342 - 528 V_{AC} ² CV Load 0 - 100% CC Line 342 - 528 V_{AC} ^{1,3} CC	6 mV < 1 mV 35 mA 4 mA	5 mV < 1 mV 12 mA 3 mA	4 mV < 1 mV 8 mA 1 mA	10mV <1mV 2mA 1mA	10 mV < 1 mV 2 mA 1 mA
Ripple + noise ⁵ Source mode: rms (BW=300 kHz) CV p-p (BW=20 MHz) CV rms (BW=300 kHz) CC p-p (BW=20 MHz) CC rms (BW=300 kHz) CV p-p (BW=20 MHz) CV rms (BW=300 kHz) CC p-p (BW=20 MHz) CC Sink mode: rms (BW=300 kHz) CV p-p (BW=20 MHz) CV rms (BW=300 kHz) CC p-p (BW=20 MHz) CC rms (BW=300 kHz) CV p-p (BW=20 MHz) CV rms (BW=300 kHz) CC p-p (BW=20 MHz) CC	33 V / 450 A 10 mV 60 mV 100 mA - 70 V / 215 A 10 mV 60 mV 100 mA - 33 V / 450 A 8 mV 50 mV 100 mA - 70 V / 215 A 8 mV 50 mV 100 mA -	100 V / 150 A 30 mV 150 mV - - 210 V / 71.5 A 20 mV 125 mV - - 100 V / 150 A 30 mV 150 mV - - 210 V / 71.5 A 20 mV 125 mV - -	167 V / 90 A 10 mV 55 mV 45 mA 200 mA 500 V / 30 A 25mV 115mV 45 mA 200 mA 167 V / 90 A 7 mV 35 mV 45 mA 200 mA 500 V / 30 A 10 mV 50 mV 90 mA 320 mA	333V / 45A 25mV 150mV 45mA 200mA 1000V / 15A 35mV 250mV 45mA 200mA 333V / 45A 15mV 75mV 60mA - 1000V / 15A 25mV 125mV 60mA -	500 V / 30 A 25 mV 150 mV 12 mA 70 mA 1500 V / 10 A 35mV 250mV 5 mA 25 mA 500 V / 30 A 15 mV 130 mV 10 mA 60 mA 1500 V / 10 A 25 mV 200 mV 3 mA 12 mA
Programming & monitoring accuracy ⁴ Voltage Current	± 0.08 % ± 0.15 %				
Temperature coefficient, per °C ^{1,5} CV CC	20 ppm 50 ppm				
Stability over 8 hours ^{1,5} 25 ± 1 °C CV CC ³	50 ppm 80 ppm				

¹ After 1 hour warm up² Remote voltage sense³ Local voltage sense⁴ Excluding INT MOD ANA⁵ Measured at full load

	SM70-CP-450	SM210-CP-150	SM500-CP-90	SM1000-CP-45	SM1500-CP-30
Programming speed ^{6, 7}					
Rise time (10 - 90%)					
Output voltage step	0 → 33 V	0 → 100 V	0 → 167 V	0 → 333 V	0 → 500 V
Load = 15 kW	2.2 ms	1.6 ms	1.5 ms	1.5 ms	1.5 ms
Load = 1500 W	1.5 ms	1.3 ms	1 ms	1 ms	1 ms
Output voltage step	0 → 70 V	0 → 210 V	0 → 500 V	0 → 1000 V	0 → 1500 V
Load = 15 kW	5.5 ms	3 ms	4.5 ms	4.5 ms	4.5 ms
Load = 1500 W	3.5 ms	2.7 ms	3.5 ms	3.5 ms	3.5 ms
Fall time (90 - 10%)					
Output voltage step	33 → 0 V	100 → 0 V	167 → 0 V	333 → 0 V	500 → 0 V
Load = 15 kW	1.5 ms	1.3 ms	0.8 ms	0.9 ms	0.8 ms
Load = 1500 W	1.5 ms	1.3 ms	0.9 ms	1.0 ms	0.9 ms
Output voltage step	70 → 0 V	210 → 0 V	500 → 0 V	1000 → 0 V	1500 → 0 V
Load = 15 kW	2.6 ms	2.5 ms	2.5 ms	2.8 ms	2.8 ms
Load = 1500 W	3.5 ms	2.5 ms	3.5 ms	3.5 ms	3.5 ms
Recovery time ^{8, 9}					
Condition	33 V, 225 → 450 A	100 V, 75 → 150 A	167 V, 45 → 90 A	333 V, 22.5 → 45A	500 V, 15 → 30 A
Recovery within	100 mV	500 mV	750 mV	2.5 V	2.8 V
di/dt of load step	5 A/μs	2.4 A/μs	0.8 A/μs	0.4 A/μs	0.25 A/μs
Time	100 μs	100 μs	100 μs	100 μs	100 μs
Maximum deviation	0.8 V	1.4 V	2.8 V	9.0 V	9.0 V
Condition	70 V, 112 → 215 A	210 V, 36 → 72 A	500 V, 15 → 30 A	1000 V, 7.5 → 15A	1500 V, 5 → 10 A
Recovery within	100 mV	250 mV	500 mV	1 V	1.2 V
di/dt of load step	2 A/μs	1.15 A/μs	0.25 A/μs	0.15 A/μs	0.085 A/μs
Time	100 μs	100 μs	150 μs	150 μs	150 μs
Maximum deviation	0.3 V	0.75 V	1.2 V	3.0 V	3.5 V
DC output capacitance					
X-capacitors (typical)	22000 μF	1170 μF	560 μF	141 μF	58 μF
Y-capacitors (typical)	950 nF	950 nF	145 nF	145 nF	145 nF
Output impedance ¹⁰					
0-1 kHz CV	< 0.75 mΩ	< 5 mΩ	< 16 mΩ	< 150 mΩ	< 250 mΩ
1-100 kHz CV	< 40 mΩ	< 40 mΩ	< 160 mΩ	< 800 mΩ	< 2 Ω
Pulsating load					
Max. tolerable AC component of load current					
f > 1 kHz	60 A _{RMS}	15 A _{RMS}	15 A _{RMS}	3 A _{RMS}	2.5 A _{RMS}
f < 1 kHz	450 A _{pk}	150 A _{pk}	90 A _{pk}	45 A _{pk}	30 A _{pk}
Hold-up time					
V _{out} = 100%, P _{out} = 15 kW	10 ms	10 ms	15 ms	15 ms	15 ms
I _{out} = 100%, P _{out} = 15 kW	10 ms	10 ms	15 ms	15 ms	15 ms
V _{out} = 100%, P _{out} = 7.5 kW	25 ms	20 ms	35 ms	35 ms	35 ms
Turn on delay ¹¹	2.5 s after mains switch is turned on, output power is available				
Inrush current ¹⁰	23 A				
Safety standards	EN 60950 / EN 61010				
Insulation	3750 V _{RMS} (1 min.) 8 mm 2500 V _{RMS} 1000 V _{DC} ¹²				3750 V _{RMS} (1 min.) 8 mm 2500 V _{RMS} 1500 V _{DC} ¹²
EMC	EN 61326-1 , class B equipment(for use in domestic establishments) EN 61326-1 , equipment for use in industrial and domestic establishments				
Environmental conditions	- 40 to + 70 °C - 20 to + 50 °C, Derate output to 75% at 60 °C Output automatically disabled at overtemperature Humidity Maximum 95% RH, non-condensing, up to 40 °C Maximum 75% RH, non-condensing, up to 50 °C IP Rating IP20 Pollution degree 2				
MTBF	500 000 hrs				

⁶ Measured on resistive load with power supply in CV mode, different conditions may influence the specified speed.

⁷ Signal latency depends on the interface used & data traffic.

⁸ Local voltage sense.

⁹ Remote sensing and long wiring may influence the values.

¹⁰ Typical

¹¹ Unit should be configured to switch on the output at startup.

¹² See "Safety Instructions" in the product manual.

	SM70-CP-450	SM210-CP-150	SM500-CP-90	SM1000-CP-45	SM1500-CP-30
Series operation Maximum total voltage Master / slave operation	Series operation not allowed		750 V ¹³ 1000 V ¹⁴ Maximum 6 units ¹⁵	Series operation not allowed	
Parallel operation Master / slave operation	Maximum 60 units				
Remote sensing Maximum voltage drop per load lead	Default 1 V, can be set to 10 V				
Limits Adjustable Voltage Current Power Fixed Voltage OverLoad level Voltage Self-Protection level			0 - 101 % 0 - 101 % 0 - 101 %		
Potentiometers Front panel control knob resolution	15 bits				
Meter scale Voltage Current Power Accuracy read output	4 digits 0.00 - 70.00V -450.0 - 450.0A -15000 - 15000W 0.2% + 2 digit	4 digits 0.0 - 210.0V -150.0 - 150.0A -15000 - 15000W 0.2% + 2 digit	4 digits 0.0 - 500.0V -90.0 - 90.0A -15000 - 15000W 0.2% + 2 digit	4 digits 0 - 1000V -45.00 - 45.00A -15000 - 15000W 0.2% + 2 digit	4 digits 0 - 1500V -30.00 - 30.00A -15000 - 15000W 0.2% + 2 digit
Mounting	Stacking of units allowed				
AC terminals (CON A)	Screw terminals for wire 4 mm ² , 3 phase + earth (no neutral)				
DC terminals (CON B1 & B2)	M12 bolts	M8 bolts			
Programming connectors (LAN)	Standard with RJ45-connector for Ethernet at rear panel, 100 Mb/s, full-duplex				
Interlock (CON F)	Input for contact at rear panel				
Cooling Audio noise level Airflow direction Thermal protection	Low noise, fan speed adapts to temperature of internal system ca. 50 dBA at full load, 25 °C ambient temperature, 1 m distance ca. 65 dBA at full load, 50 °C ambient temperature, 1 m distance From left to right Output shuts down in case of insufficient cooling (over temperature indication in display)				
Dimensions Front panel: h x w behind front panel: h x w x d	132 x 483 mm (19", 3 U) 128 x 448 x 591 mm (excluding feet) <i>No additional depth is required with optional interfaces assembled</i>				
Weight	27 kg				

CV = Constant Voltage

CC = Constant Current

CP = Constant Power

Specifications measured at $T_{amb} = 25 \pm 5 \text{ °C}$ and $V_{in} = 400 V_{AC}$, 3 phase, 50 Hz unless otherwise noted.

The information in this document is subject to change without notice.

¹³ Units delivered before Q4 / 2018. Contact factory for upgrading to enable 1000 V series operation for older units.¹⁴ Units delivered in Q4 / 2018 or later.¹⁵ See "Safety Instructions" in the product manual.

Operating range

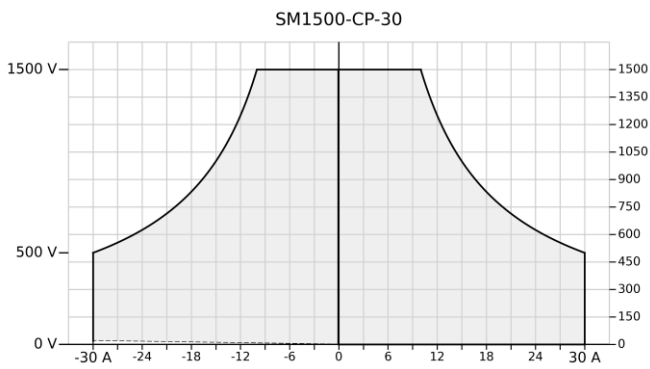
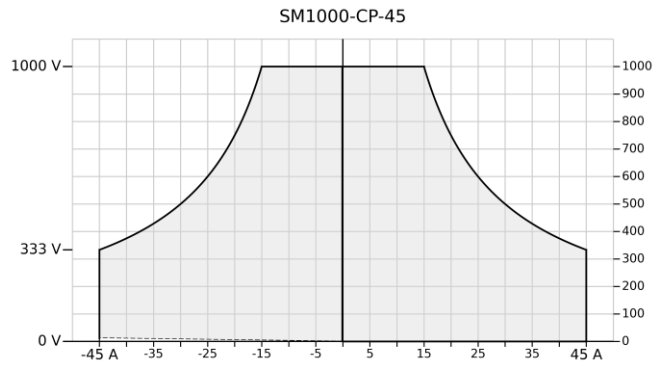
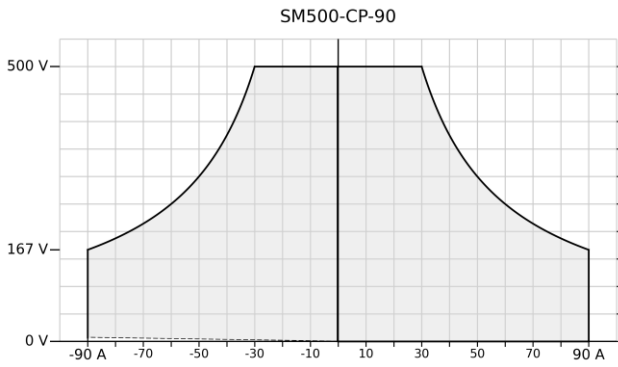
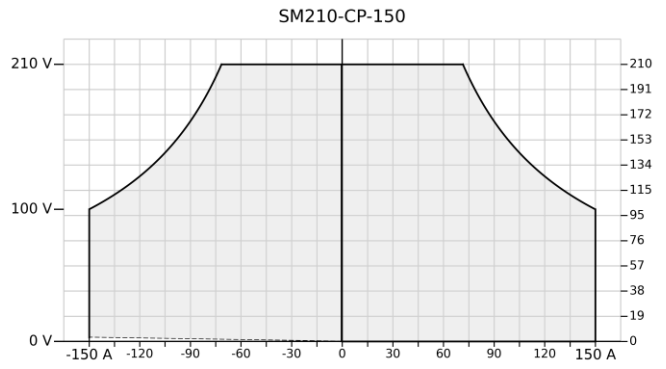
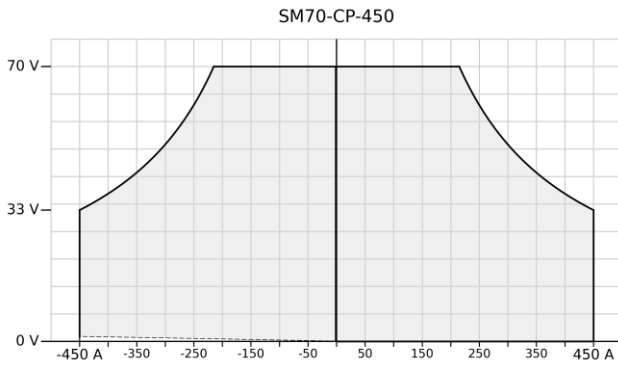

Dimensions

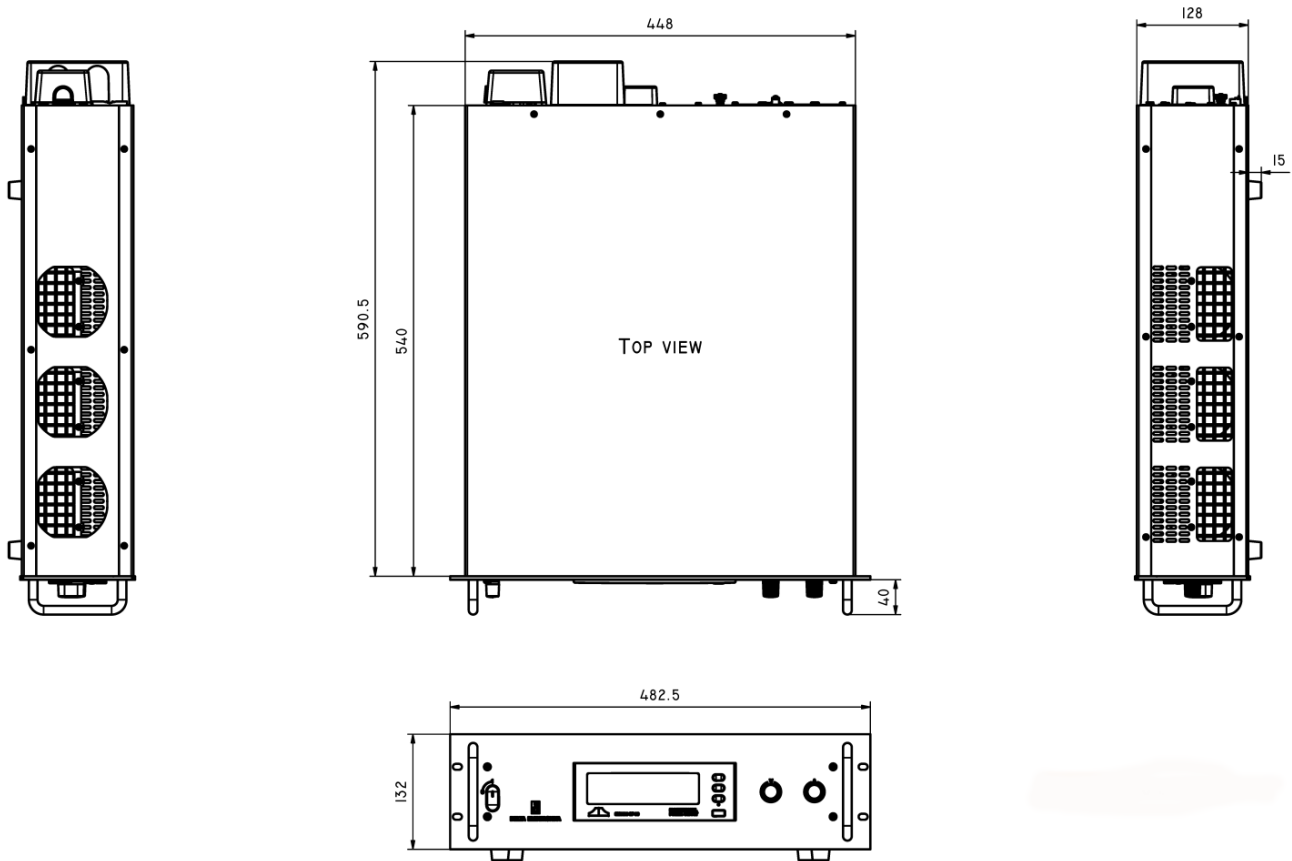

Rear view

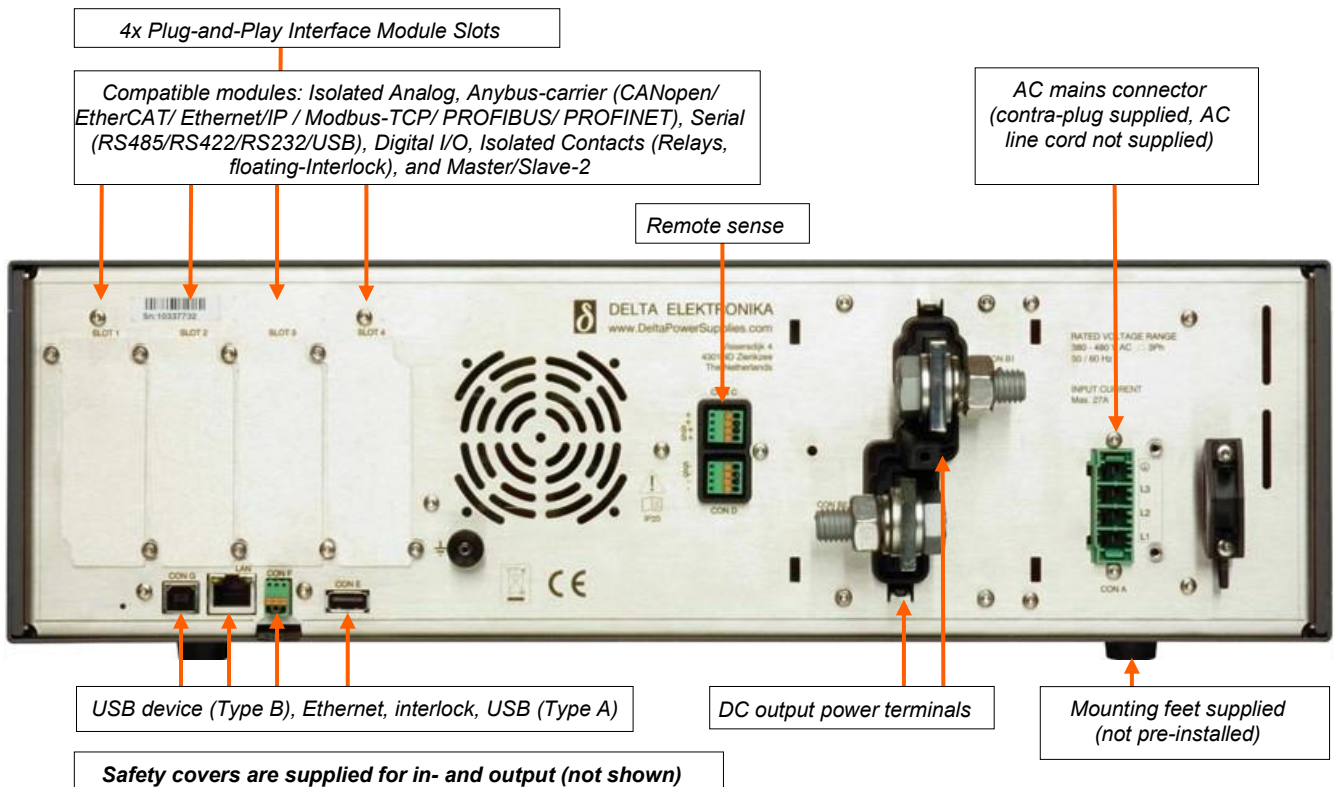

Typical Applications

- PV simulation and inverter testing
- Automotive test systems
- Automotive battery simulation
- Controlled battery (dis)charge test
- ATE in industrial production lines
- Precision current sources
- PWM-controlled DC motor testing
- Renewable-energy systems
- Plasma chambers
- Lasers
- Aerospace applications
- Defense / military applications

Standard Features



Bi-Directional Two-Quadrant Output

Full-power bidirectional two-quadrant operation keeps the DC output voltage constant whether power is sourced or sunk. Ideal for PWM-controlled DC motors and ATE systems.



Digital CV- and CC-Settings

Long-life digital encoders on the front panel provide precise CV/CC setting with coarse/fine adjustment and full front-panel lock (including CV/CC knobs).



High Voltage Isolation

High DC output isolation allows floating operation up to 1000 V for SM70-CP-450, SM210-CP-150, SM500-CP-90 and SM1000-CP-45, and up to 1500 V for SM1500-CP-30.



Sequencer and Function Blocks

Includes a sequencer for standalone automation or waveform generation. Function blocks support PV simulation, lead-less sensing and internal resistance function.



Ethernet Interface

Ethernet interface for programming and monitoring (SCPI), including an integrated web interface for remote control.



USB-Input

Feature not yet available. Front and rear USB inputs (Host / Type-A) are planned for exchanging settings and waveforms. Sequences can be uploaded via the web interface.

Interfaces



Plug-and-play extension modules

Interfacing and functional capabilities of the power supply can be extended at any time by inserting modules. Four slots are available at the rear of the power supply unit. Consult the [interfaces data sheet](#) for more information.

Modules:

- **Isolated Analog programming** (INT-MOD-ANA)
High speed and accurate analog programming and monitoring
- **Anybus-carrier** (INT-MOD-ANY)
Carrier for AnyBus CompactCom 40 fieldbus inserts:
CANopen, EtherCAT, Ethernet/IP, Modbus-TCP, POWERLINK, PROFIBUS, PROFINET
- **Digital I/O** (INT-MOD-DIG)
Interacts with sequencer and Ethernet programming.
- **Isolated contacts** (INT-MOD-CON)
Programmable relays and floating interlock
- **Serial communication** (INT-MOD-SER)
RS232, RS485, RS422, USB
- **Master/Slave** (INT-MOD-M/S-2)
Series/parallel output functionality.
Assembly kits for parallel (M/S-PAR-SET) and series (M/S-SER-SET) operation are available for multi-unit systems. The number of units that can be connected in series or parallel depends on the power supply model.

Ordering Information

Visit our [website to request a quote](#), free of charge.

Alternatively, contact us directly or get in touch with one of our [authorized distributors](#).

Delta Elektronika B.V.
Vissersdijk 4, 4301ND
Zierikzee
The Netherlands

T: +31 111 413656

E: via [contact form on our website](#)

W: www.DeltaPowerSupplies.com

