



# ES150–series

- **ES015-10**
- **ES030-5**
- **ES075-2**
- **ES0300-0.45**

## **Product Manuals and Driver & Example Software**

For several Applications, build-in Options and Interfaces there are Application Notes, separate Product Manuals and Driver & Example Software available on our website. See [PRODUCTS\ES150\DOWNLOADS](#)

## **PRODUCT MANUAL**

Contents:

- 1 – **Safety Instructions**
- 2 – **Sicherheitshinweise**
- 3 – **Consignes de Sécurité**
- 4 – **General**
- 5 – **Operating**
- 6 – **Maintenance & Trouble Shooting**
- 7 – **Options**
- 8 – **EU Declaration**

# 1 SAFETY INSTRUCTIONS - ES150-series

## 1.1 Caution

The following safety precautions must be observed during all phases of operation, service and repair of this equipment. Failure to comply with the safety precautions or warnings in this document violates safety standards of design, manufacture and intended use of this equipment and may impair the built-in protections. Delta Elektronika shall not be liable for user's failure to comply with these requirements.

## 1.2 Installation Category

The Delta Elektronika power supplies have been evaluated to installation category II (Over voltage category II).

## 1.3 Grounding of Mains Terminals (AC Power Terminals)

This product is a safety Class 1 unit. To minimize shock hazard, the unit must be connected to the AC Power Supply mains through a three-conductor power cable, with the ground wire firmly connected to an electrical ground (safety ground) at the power outlet.

For units designed to be hard-wired to the mains supply, the protective earth terminal must be connected to the safety electrical ground before another connection is made. Any interruption of the protective ground conductor, or disconnection of the protective earth terminal will cause a potential shock hazard that might cause personal injury.

## 1.4 Grounding of DC Power Terminals

If the DC power terminal of a unit is specified to sink or source to a maximum of 60VDC, and either the 'minus' or 'plus' DC power terminal is grounded, the voltage on the following connections can be considered safe:

- DC power terminals and sense connections.
- programming/monitor/status-signals
- all Delta Elektronika interfaces.

**Warning!** When the 'plus' DC power terminal can exceed 60VDC in respect to the 'minus' DC power terminal, additional external measures must be taken to ensure safety isolation of the DC power terminals and sense connections.

**Warning!** When the 'minus' DC power terminal of the unit can exceed 60VDC / 42.4Vpk in respect to ground, additional external measures must be taken to ensure safety isolation of the following:

- DC power terminals and sense connections.
- programming/monitor/status-signals.
- interfaces with operation isolation.
- non-isolated interfaces.

**Caution 1:** If a low voltage unit has both DC power terminals floating, or if the DC terminals are in series with an external high AC or DC voltage, the 'minus' DC power terminal can exceed the safe value in respect to ground as specified in the above warning!

**Caution 2:** Although a high voltage unit is set to a safe voltage below 60VDC, for safety it must always be considered as a high voltage unit! Wrong operation, a programming error or an external defect can result in an unsafe high DC output voltage.

**Caution 3:** when programming a high voltage unit directly via a PC or a network connection, either ground the 'minus' DC power terminal or use a safety isolated interface!

For more information regards Grounding & Safety, see the online application note "*Safe operation of a power supply*".

## 1.5 Fuses

Fuses to be changed by authorized Delta Elektronika service personnel only, for continued protection against risk of fire.

## 1.6 AC Input Ratings

Do not use an AC Supply which exceeds the AC input voltage and frequency rating of this unit. The AC input voltage and frequency rating of the Delta Elektronika power supply series are stated in the accompanying datasheet.

## 1.7 Live Circuits

Operating personnel should not remove the unit covers. No internal adjustment or component replacement is allowed by non-Delta Elektronika qualified personnel. Never replace components with the power cable connected. To avoid injuries, always disconnect power, remove external voltage sources and discharge circuits before touching components.

## 1.8 Parts Substitutions & Modifications

Parts substitutions and modifications are allowed by authorized Delta Elektronika service personnel only. For repairs the unit must be returned to a Delta Elektronika service facility.

## 1.9 Removal of (safety) covers

Safety cover(s) are used to cover potentially hazardous voltages.

Observe the following when removing safety cover(s):

- Switch off the unit and disconnect the unit from the AC mains supply and from the DC power application.
- Wait for 5 minutes to allow internal capacitors to discharge, then unscrew and remove the cover(s).
- Always place the cover(s) back before connecting the unit to the mains supply again.

### 1.10 Handling and mounting

**Warning!** Risk of cutting: unit has sharp edges and corners!

**Warning!** No wall mounting or ceiling mounting allowed! Risk of crushing under unit. Only mount unit horizontally, place on a stable surface or use rack mounting.

### 1.11 Cooling, thermal burn

Proper air flow is required for cooling of the unit. This enables operation at full power and a longer life time. If the unit gets over heated, the power will shut down until unit has cooled down again.

**Warning!** Top cover and can get hot. Avoid touching this while operating the unit at high power!

**Warning!** Do not block cooling openings. Do not try to enter openings by any object.

**Warning!** Do not (dis)connect cables to the DC power terminals while the unit is on. Sudden making or breaking of high DC currents can cause large sparks, even at low voltages. Risk of thermal burn and fire!

### 1.12 Electro medical devices

**Warning!** High currents can run through the DC power terminals. These currents cause strong magnetic fields. Do not come near if you have an electro medical device such as a pacemaker.

### 1.13 Environmental Conditions

- The Delta Elektronika power supplies safety approval applies to the following operating conditions:
- Usage : Indoor use only.  
**Warning!** Not intended to be used in the presence of children or animals!
- Ambient temperature : -20 to 50 °C.
- Maximum relative humidity : 95%, noncondensing, up to 40 °C, 75%, noncondensing, up to 50 °C.
- Altitude : Do not use above 2000 m sea level.  
**Warning!** Electrical Creepage & Clearance not valid for higher altitudes!
- Pollution degree : 2

### 1.14 Symbols & markings



*Caution risk of electrical Shock.*



*Instruction manual symbol. The instrument will be marked with this symbol when it is necessary for the user to refer to the instruction manual.*



*Protective ground conductor terminal.*



*Off (supply).*



*On (supply).*

### 1.16 Canada

This product has been tested to the requirements of CAN/CSA-C22.2 No. 61010.1, second edition, including Amendment 1, or a later version of the same standard incorporating the same level of testing requirements.

### 1.17 cTUVus



## WEEE (Waste Electrical & Electronic Equipment)

### 1.15 Correct Disposal of this Product

Applicable in the European Union.



This marking shown on the product, its packing or its literature indicates that it should not be disposed with other wastes at the end of its working life but should be collected separately to recycle it responsibly to promote the sustainable reuse of material resources.

## 2 SICHERHEITSHINWEISE – ES150-series

### 2.1 Vorsicht

Die folgenden Sicherheitsvorkehrungen müssen in allen Betriebs-, Service- und Reparaturphasen dieses Geräts befolgt werden. Die Nichteinhaltung der Sicherheitsvorkehrungen oder Warnungen in diesem Dokument verstößt gegen die Sicherheitsstandards im Hinblick auf Bauart, Produktion und vorgesehene Nutzung dieses Geräts und kann die eingebauten Schutzvorrichtungen beschädigen. Delta Elektronik haftet nicht dafür, wenn der Nutzer diesen Anforderungen nicht nachkommt.

### 2.2 Installationskategorie

Die Delta Elektronik Stromversorgungen wurden der Installationskategorie II (Überspannungskategorie II) zugeordnet.

### 2.3 Erdung der Netzanschlussklemmen (AC-Einspeiseklemmen)

Dieses Produkt ist ein Gerät der Sicherheitsklasse 1. Um die Gefahr eines elektrischen Schlags zu minimieren, muss das Gerät mit einem Dreileiter-Stromkabel mit dem AC-Stromversorgungsnetz verbunden werden. Hierbei muss der Schutzleiter fest mit einem elektrischen Erdungsanschluss (Schutzleiter) an der Stromquelle verbunden sein. Bei Geräten, die fest mit dem Versorgungsnetz verdrahtet werden, muss die Schutzerdungsklemme mit dem Sicherheitserdungsanschluss verbunden werden, bevor eine andere Verbindung hergestellt wird. Eine Unterbrechung des Schutzleiters oder eine Trennung der Schutzerdungsklemme kann zu einem elektrischen Schlag führen, der zur Verletzung von Personen führen kann.

### 2.4 Erdung der DC-Anschlussklemmen

Wenn die DC-Anschlussklemme eines Geräts dafür ausgelegt ist, maximal 60 VDC zu empfangen oder zu beziehen und entweder die 'minus' oder 'plus' DC-Anschlussklemme geerdet ist, kann die Spannung als sicher angesehen werden für:

- DC-Anschlussklemmen und Sense-Anschlüsse.
- Programmierung-/Monitor-/Status-Signale.
- Alle Delta Elektronik Schnittstellen.

**Warnung!** Wenn die 'plus' DC-Anschlussklemme im Verhältnis zur 'minus' DC-Anschlussklemme 60 VDC überschreiten kann, müssen zusätzliche externe Maßnahmen ergriffen werden, um die Sicherheitsisolation der DC-Anschlussklemmen und Sense-Verbindungen sicherzustellen.

**Warnung!** Wenn die 'minus' DC-Anschlussklemme im Verhältnis zur Erdung 60 VDC/42,4 Vpk überschreiten kann, müssen zusätzliche externe Maßnahmen ergriffen werden, um die Sicherheitsisolation sicherzustellen für:

- DC-Anschlussklemmen und Sense-Anschlüsse.
- Programmierung/Monitor/Status-Signale.
- Schnittstellen mit Funktionale Isolation, Schnittstellen ohne Sicherheitsisolation.

**Vorsicht 1:** Falls beide DC-Anschlussklemmen eines Niederspannungsgerätes potentialfrei sind oder falls die DC-Klemmen in Reihe mit einer externen AC- oder DC-Hochspannung geschaltet sind, kann die 'minus' DC-Anschlussklemme den sicheren Wert in Bezug auf die Erdung wie in der Warnung oben spezifiziert überschreiten.

**Vorsicht 2:** Obwohl ein Hochspannungsgerät mit einer sicheren Spannung unter 60 VDC betrieben wird, muss es zur Sicherheit immer als Hochspannungsgerät angesehen werden! Falsche Bedienung, ein Programmierfehler oder ein externer Fehler können zu einer unsicheren, hohen DC-Ausgangsspannung führen.

**Vorsicht 3:** Wenn ein Hochspannungsgerät direkt über ein PC oder Netzwerk Verbindung programmiert wird, muss oder die 'minus' DC-Anschlussklemme mit PE verbunden wurden, oder muss ein Schnittstelle mit Sicherheitsisolation gebraucht wurden! Für weitere Informationen und Schaltpläne hinsichtlich Erdung und Sicherheit, siehe den online Applikationshinweis '*Safe operation of a power supply*'.

### 2.5 Gefahr eines elektrischen Schlags

Das Berühren der Kontakte des Netzsteckers oder der Kabel direkt nach der Trennung vom Netz kann zu einem elektrischen Schlag führen. Und aufgrund von geladenen X-Kondensatoren, kann gefährliches Potential zwischen 'plus' oder 'minus' DC-Anschlussklemme mit PE bestehen oder entstehen. Auch wenn die DC-Anschlussklemmen ausgeschaltet sind, aber das Gerät noch eingeschaltet ist. Daher niemals gleichzeitig PE und einen der DC-Anschlussklemmen berühren mit bloßen Händen.

### 2.6 Sicherungen

Sicherungen dürfen ausschließlich von autorisiertem Delta Elektronik-Service-Personal ausgetauscht werden, um Brandgefahr dauerhaft auszuschließen.

### 2.7 AC-Eingangsleistung

Verwenden Sie keine AC-Versorgung, welche die AC-Eingangsspannung und Frequenzleistung dieses Geräts überschreitet. Die AC-Eingangsspannung und Frequenzleistung der Delta Elektronik-Stromversorgungsserie sind im beiliegenden Datenblatt angegeben.

### 2.8 Spannungsführenden Stromkreise

Bedienungspersonal darf die Geräteabdeckungen nicht entfernen. Interne Einstellungen oder Bauteilaustausche sind ausschließlich qualifiziertem Personal von Delta Elektronik gestattet. Bauteile nie bei eingestecktem Stromkabel austauschen. Um Verletzungen zu vermeiden, vor dem Berühren von Bauteilen immer den Strom trennen, externe Spannungsquellen entfernen und Stromkreise entladen.

## 2.9 Teileaustausch & Modifikationen

Teileaustausch und Modifikationen sind ausschließlich autorisiertem Delta Elektronika-Service-Personal gestattet. Reparaturen am Gerät dürfen nur durch eine Delta Elektronika-Serviceeinrichtung durchgeführt werden.

## 2.10 Entfernung von (Sicherheits-) Abdeckungen

Sicherheitsabdeckung(en) werden verwendet, um potenziell gefährliche Spannungen abzudecken. Beachten Sie Folgendes, wenn Sie die Sicherheitsabdeckung(en) entfernen:

- Gerät ausschalten, Gerät von dem AC-Versorgungsnetz und DC-Anwendung trennen.
- Warten Sie 5 Minuten um interne Kondensatoren zu entladen. Abschrauben und entfernen von Abdeckung(en).
- Bevor Sie das Gerät wieder mit dem Versorgungsnetz verbinden, montieren Sie vorher jedes Mal die Abdeckung(en).

## 2.11 Handhabung und Montage

**Warnung!** Risiko des Schneidens: Einheit hat scharfe Kanten und Ecken!

**Warnung!** Keine Wandmontage oder Deckenmontage erlaubt! Gefahr der Zerkleinerung unter Einheit. Nur Einheit horizontal montieren, auf eine stabile Oberfläche stellen oder Rack-Montage verwenden.

## 2.12 Kühlung, thermische Verbrennung

Für die Kühlung des Geräts ist ein richtiger Luftstrom erforderlich. Dies ermöglicht den Betrieb bei voller Leistung und einer längeren Lebensdauer. Wenn das Gerät überhitzt wird, schaltet sich die Stromversorgung herunter, bis das Gerät wieder abgekühlt ist.

**Warnung!** Top-Abdeckung und Lüfter Auspuffs können heiß werden. Vermeiden Sie diese zu berühren, während Sie das Gerät mit hoher Leistung bedienen!

**Warnung!** Blockieren Sie keine Lüfter Öffnungen. Versuchen Sie nicht, Lüfter Öffnungen durch ein Objekt zu betreten, um Lüfter zu behindern.

**Warnung!** Schließen Sie keine Kabel an die DC-Anschlussklemmen an, während das Gerät eingeschaltet ist. Plötzliches Machen oder Brechen von hohen Gleichstrom kann große Funken verursachen, auch bei niedriger Spannung. Gefahr von thermischen Verbrennung und Feuer!

## 2.13 Elektromedizinische Geräte

**Warnung!** Hohe Ströme können durch die DC-Anschlussklemmen laufen. Diese Ströme verursachen starke Magnetfelder. Kommen Sie nicht in die Nähe, wenn Sie ein elektromedizinisches Gerät wie einen Herzschrittmacher haben.

## 2.14 Umgebungsbedingungen

Die Stromversorgungssicherheitszulassung von Delta Elektronika gilt für die folgenden Betriebsbedingungen:

- Gebrauch : Nur Innengebrauch. **Warnung!** Nicht für die Verwendung in Gegenwart von Kindern oder Tieren vorgesehen!
- Umgebungstemperatur : -20 bis 50 °C.
- Maximale relative Luftfeuchtigkeit : 95%, nicht kondensierend, bis zu 40 °C, 75%, nicht kondensierend, bis zu 50 °C
- Höhe : Nicht über 2000 m Meeresspiegel verwenden.  
**Warnung!** Elektrische Creepage & Clearance nicht gültig für größere Höhen!
- Verschmutzungsgrad : 2

## 2.15 Symbole und Markierungen



Vorsichtsgefahr bei elektrischen Schlag.



PE-leiterklemme.



Bedienungsanleitung Symbol. Das Gerät wird mit diesem Symbol gekennzeichnet, wenn der Benutzer auf die Bedienungsanleitung verweisen muss.



Aus (Versorgungsnetz).



Ein (Versorgungsnetz).

## 2.16 Canada



This product has been tested to the requirements of CAN/CSA-C22.2 No. 61010.1, second edition, including Amendment 1, or a later version of the same standard incorporating the same level of testing requirements.

## 2.17 cTUVus



## WEEE (Waste Electrical & Electronic Equipment)

### 2.18 Korrekte Entsorgung dieses Produkts



Anwendbar in der Europäischen Union.

Diese Kennzeichnung auf dem Produkt, seiner Verpackung oder seiner Literatur weist darauf hin, dass es am Ende seiner Lebensdauer nicht mit anderen Abfällen entsorgt, sondern separat gesammelt werden sollte, um es verantwortungsvoll zu recyceln, um die nachhaltige Wiederverwendung von Material zu fördern.

### 3 CONSIGNES DE SÉCURITÉ – Série ES150

#### 3.1 Mise en garde

Les précautions de sécurité suivantes doivent être suivies dans toutes les phases de fonctionnement, d'entretien et de réparation de cet appareil. Le non-respect des précautions de sécurité ou des avertissements contenus dans le présent document enfreint les normes de sécurité concernant la conception, la production et l'utilisation prévue de cet appareil et peut endommager les dispositifs de protection intégrés. Delta Elektronika n'est pas responsable si l'utilisateur ne se conforme pas à ces exigences.

#### 3.2 Catégorie d'installation

Les alimentations Delta Elektronika ont été affectées à la catégorie d'installation II (catégorie de surtension II).

#### 3.3 Mise à la terre des bornes de raccordement secteur (bornes d'alimentation CA)

Ce produit est un appareil de classe 1. Pour minimiser le risque de choc électrique, l'appareil doit être connecté au réseau d'alimentation CA à l'aide d'un câble d'alimentation à trois fils. Dans ce cas, le conducteur de protection doit être fermement connecté à une connexion de mise à la terre électrique (conducteur de protection) à la source d'alimentation. Pour les appareils câblés au réseau d'alimentation, la borne de mise à la terre de protection doit être connectée au connecteur de mise à la terre de sécurité avant d'effectuer une autre connexion. Une interruption du conducteur de protection ou une séparation de la pince de mise à la terre de protection peut entraîner un choc électrique pouvant blesser les personnes.

#### 3.4 Mise à la terre des bornes CC

Si la borne CC d'un appareil est conçue pour recevoir ou obtenir un maximum de 60 VDC et que la borne CC « moins » ou « plus » est mise à la terre, la tension peut être considérée comme sûre pour :

- Bornes CC et connecteurs Sense.
- Signaux de programmation/moniteur/état.
- Toutes les interfaces Delta Elektronika

**Avertissement!** Si le bornier CC « plus » peut dépasser 60 VDC par rapport au bornier CC « moins », des mesures externes supplémentaires doivent être prises pour assurer l'isolation de sécurité des bornes CC et des connexions de détection.

**Avertissement!** Si le terminal CC « moins » peut dépasser 60 VDC/42,4 Vpk par rapport à la mise à la terre, des mesures externes supplémentaires doivent être prises pour assurer l'isolation de sécurité pour :

- les bornes CC et les connecteurs Sense.
- Signaux de programmation/moniteur/état, InterLock, connecteurs maître/esclave, relais ACF/DCF.
- Interfaces avec isolation fonctionnelle, interfaces sans isolation de sécurité.

**Attention 1:** Si les deux bornes CC d'un dispositif basse tension sont sans potentiel ou si les bornes CC sont connectées en série avec une haute tension EXTERNE CA ou CC, le bornier CC « moins » peut dépasser la valeur de sécurité en termes de mise à la terre comme spécifié dans l'avertissement ci-dessus.

**Attention 2:** Bien qu'un appareil haute tension fonctionne à une tension de sécurité inférieure à 60 VDC, il doit toujours être considéré comme un appareil haute tension pour la sécurité! Un fonctionnement incorrect, une erreur de programmation ou une erreur externe peut entraîner une tension de sortie CC incertaine et élevée.

**Attention 3:** Si un appareil haute tension est programmé directement via un PC ou une connexion réseau, ou si le terminal CC « moins » doit être connecté au PE, ou si une interface avec isolation de sécurité doit être nécessaire ! Pour plus d'informations et des schémas de circuit concernant la mise à la terre et la sécurité, voir la note d'application en ligne « Fonctionnement sûr d'une alimentation.

#### 3.5 Risque de choc électrique

Toucher les contacts de la fiche d'alimentation ou des câbles immédiatement après la déconnexion du secteur peut entraîner un choc électrique. Et en raison des condensateurs X chargés, un potentiel dangereux entre le terminal CC « plus » ou « moins » et le PE peut exister ou survenir. Même si les bornes CC sont éteintes, mais que l'appareil est toujours allumé. Par conséquent, ne touchez jamais PE et l'un des terminaux DC à mains nues en même temps.

#### 3.6 Fusibles

Les fusibles ne peuvent être remplacés que par le personnel de service autorisé de Delta Elektronika afin d'éliminer définitivement le risque d'incendie.

#### 3.7 Alimentation d'entrée CA

N'utilisez pas une alimentation CA qui dépasse la tension d'entrée CA et la puissance de fréquence de cet appareil. La tension d'entrée CA et la puissance de fréquence de la série d'alimentations Delta Elektronika sont spécifiées dans la fiche technique ci-jointe.

#### 3.8 Circuits sous tension

Les opérateurs ne doivent pas retirer les couvercles de l'appareil. Les réglages internes ou les remplacements de composants ne sont autorisés qu'au personnel qualifié de Delta Elektronika. Ne remplacez jamais les composants par le câble d'alimentation branché. Pour éviter les blessures, débranchez toujours le courant avant de toucher les composants, retirez les sources de tension externes et les circuits de décharge.

#### 3.9 Remplacement et modifications des pièces

Le remplacement et les modifications des pièces ne sont autorisés qu'au personnel de service agréé de Delta Elektronika. Les réparations de l'appareil ne peuvent être effectuées que par un centre de service Delta Elektronika.

### 3.10 Retrait des couvercles (de sécurité)

Les couvercles de sécurité sont utilisés pour couvrir les tensions potentiellement dangereuses.

Lorsque vous retirez le ou les couvercles de sécurité, tenez compte des éléments suivants :

- Éteignez l'appareil, débranchez l'appareil du réseau d'alimentation CA et débranchez l'application CC.
- Attendez 5 minutes pour décharger les condensateurs internes. Dévissez et retirez-le(s) couvercle(s).
- Avant de reconnecter l'appareil au réseau d'alimentation, installez-le(s) couvercle(s) à chaque fois.

### 3.11 Manipulation et montage

**Attention!** Le poids unitaire est de 10 kg! Lors du déballage ou du changement par précaution: Soulevez avec 2 personnes ou utilisez un outil de levage. Danger d'écraser les membres sous l'unité. Risque de coupe: L'unité a des arêtes vives et des coins!

**Attention!** Aucun montage mural ou au plafond n'est autorisé! Danger d'écrasement sous l'unité. Montez uniquement l'unité horizontalement, placez-la sur une surface stable utilisez un support en rack.

### 3.12 Refroidissement, combustion thermique

Un flux d'air approprié est nécessaire pour refroidir l'appareil. Cela permet un fonctionnement à pleine puissance et une durée de vie plus longue. Si l'appareil surchauffe, l'alimentation s'éteindra jusqu'à ce que l'appareil ait refroidi à nouveau.

**Attention!** Le couvercle supérieur peut devenir chauds. Évitez de les toucher lorsque vous utilisez l'appareil avec une puissance élevée!

**Attention!** Ne bloquez pas les ouvertures ou les bouches d'aération. N'essayez pas d'entrer dans les ouvertures des ventilateurs à travers un objet pour obstruer les ventilateurs. Les cheveux longs peuvent rester coincés dans un ventilateur, portez un filet à cheveux si vous avez les cheveux longs.

**Attention!** Ne connectez pas de câbles aux bornes CC lorsque l'appareil est allumé.

Soudain, faire ou casser un courant continu élevé peut provoquer de grandes étincelles, même à basse tension. Danger de combustion thermique et d'incendie!

### 3.13 Équipement électromédical

**Attention!** Des courants élevés peuvent traverser les bornes CC. Ces courants provoquent de forts champs magnétiques. Ne vous approchez pas si vous avez un appareil électromédical comme un stimulateur cardiaque.

### 3.14 Conditions ambiantes

L'approbation de sécurité de l'alimentation de Delta Elektronika s'applique aux conditions de fonctionnement suivantes :

- Utilisation : Utilisation à l'intérieur seulement. **Attention!** Non destiné à être utilisé en présence d'enfants ou d'animaux!
- Température ambiante: -20 à 50 °C.
- Humidité relative max: 95%, sans condensation, jusqu'à 40 °C, 75 %, sans condensation, jusqu'à 50 °C
- Altitude: Ne pas utiliser au-dessus de 2000 m niveau de la mer.  
**Attention!** Creepage & Clearance électrique non valable pour les altitudes plus élevées!
- Degré de contamination: 2

### 3.15 Symboles et marqueurs



Risque de prudence en cas de choc électrique.



Terminal conducteur de terre de protection.



Icône du manuel d'instructions. L'appareil est marqué de cette icône lorsque l'utilisateur doit se référer au manuel d'instructions.



Désactivé (réseau d'approvisionnement).



A (réseau d'approvisionnement).

### 3.17 Canada

This product has been tested to the requirements of CAN/CSA-C22.2 No. 61010.1, second edition, including Amendment 1, or a later version of the same standard incorporating the same level of testing requirements.

### 3.18 cTUVus



## DEEE (Déchets d'équipements électriques et électroniques)

### 3.16 Élimination correcte de ce produit

Applicable dans l'Union européenne.



Cet étiquetage sur le produit, son emballage ou sa documentation indique qu'il ne doit pas être éliminé avec d'autres déchets en fin de vie, mais doit être collecté séparément afin de le recycler de manière responsable afin de promouvoir la réutilisation durable des matériaux.

## 4 GENERAL

### 4.1 OUTPUT

- The ES015-10, ES030-5, ES075-2 and ES0300-0.45 can either be used as a constant voltage source with current limiting or as a constant current source with voltage limiting.
- The change of mode occurs sharply at the crossing of the voltage and current settings. Fig. 4 - 1 shows the output ranges.

### 4.2 OVERLOAD PROTECTION

- The power supply is fully protected against all overload conditions, including short circuit.

### 4.3 INPUT VOLTAGE

- The power supplies have a wide input voltage range.
- The units can also be used as a DC/DC converter.

### 4.4 INPUT CURRENT

- The units have active power factor correction (PFC). The input current will therefore almost be a sine wave. This means that the rms-value and the harmonic distortion of the input current will be relatively low.

### 4.5 EFFICIENCY

- The efficiency is very high and constant over a wide output current range. High efficiency also means low power loss and low heat generation.

### 4.6 CV REGULATION

- The CV-load regulation should be measured directly on the output terminals (see fig. 4 - 2). A few cm of cable can have a voltage drop of several mV (at high current!).

### 4.7 CC REGULATION

- For accurate CC-load regulation, the optional external voltage sensing is not recommended.

### 4.8 RIPPLE & NOISE

- The output ripple is very low with almost no spikes. The ripple voltage has to be measured directly on the output terminals using a probe with very short connections (to avoid pick up of magnetic fields) (see fig. 4 - 3).
- Note: to get reliable results, the background noise level should be lower than the output ripple.

### 4.9 PROGRAMMING INPUTS

- The output voltage and current can be programmed by an external analog voltage. This programming is very accurate and linear. The levels are all standardized on 5V.
- The inputs have a protection circuit formed by a series resistor and a parallel Zener (see fig. 4 - 4). The capacitor limits the speed to a safe value. Note that the analog inputs (and outputs) are not floating, but the common is connected to the negative output terminal. Wrong connection of  $\emptyset$  can cause earth loops which can trip the fuse. After removing the fault, the fuse will reset (PTC-fuse). To prevent earth loops, use isolated programming with the ISO AMP MODULE.
- The programming mode (program and manual) can be selected at the rear panel.

### 4.10 Ethernet / RS232 PROGRAMMING

- The Delta Elektronika PSC-ETH and PSC-232 controllers can be built inside the unit.
- Voltage and current can easily be programmed and read back. Also all the status outputs can be read by the computer.

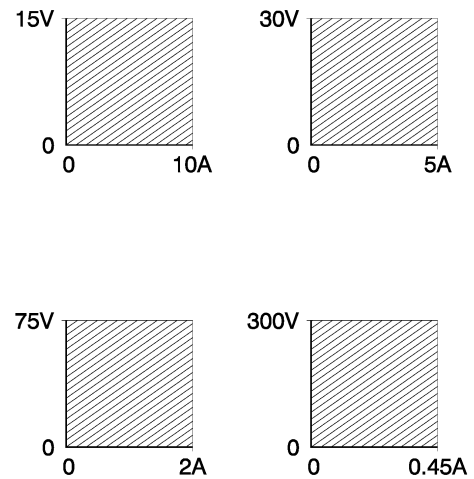

fig 4 - 1  
The output ranges.  
Every point in hatched area can be used.

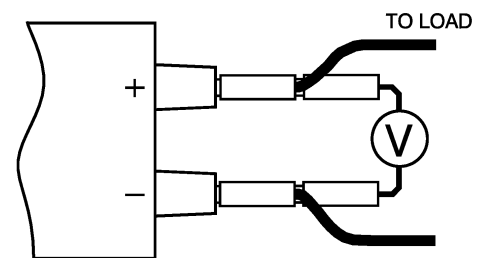

fig 4 - 2  
Measuring CV-regulation.

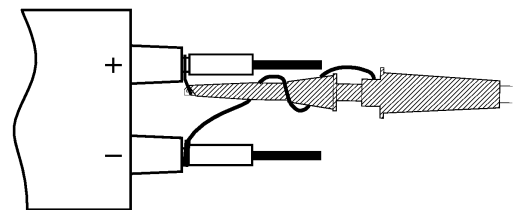

fig 4 - 3  
Measuring ripple voltage.

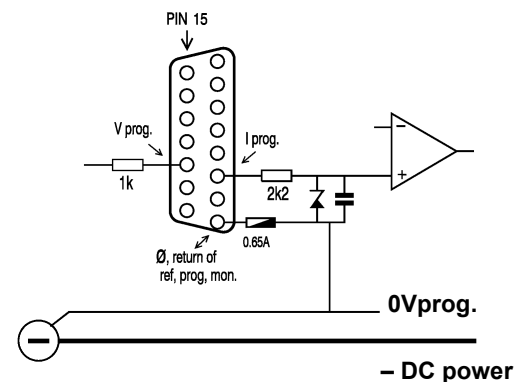

fig 4 - 4  
Programming inputs  
(internal circuit).

**Warning!** 0Vprog. and Minus DC power are internally connected.

### 4.11 MONITORING OUTPUTS

- The monitor outputs give a voltage 0 - 5 V proportional to the output current or voltage. The output current can easily be measured without an external shunt using the CC monitor (see fig. 4 - 6).

The monitor outputs are buffered by op-amp's and protected by zener diodes in parallel (see fig. 4 - 7). The table below shows the impedance of the monitoring outputs. The monitoring and the reference outputs are stable for capacitive loads up to 2  $\mu$ F, for larger values a 22 Ohm resistor should be put in series.

- Note: in case of a pulsating load, the I monitor voltage will not exactly match the output current. This is mainly caused by the current through the output capacitors. Remote sensing will worsen this effect.

Output	pin	Ro	Io max
Vref	9	15 Ohm	10 mA
Vmon	10	20 Ohm	10 mA
Imon	2	20 Ohm	10 mA
+12V	7	100 Ohm	25 mA
$\emptyset$	1	1.2 Ohm	

table 4 - 1 Outputs on programming connector.

### 4.12 +12V ON PROGRAMMING CONNECTOR

- The +12V on the programming connector can be used for supplying external circuits like the MASTER / SLAVE ADAPTER. The output is current limited but should not be overloaded.

### 4.13 CC STATUS OUTPUT

- The CC status output has an open output voltage of 5 V and a short circuit current of 10 mA. This makes it possible to drive directly: an opto-coupler, a TTL gate or a CMOS gate.

### 4.14 REMOTE SHUTDOWN

- A voltage of +5V on the Remote Shutdown input on the programming connector will switch off the power circuit of the unit. In standby mode the power supply consumes very little power.
- It is also possible to use a relay contact or a switch to shut down the unit: connect a switch between Vref and Remote Shutdown (pin 9 and 5).

### 4.15 PROGRAMMING RESPONSE TIME

- The response time is measured with a step wave form at the CV prog. input. The load is resistive. Programming from a low to a high output voltage is nearly load independent, but programming down to a low voltage takes more time on lighter loads. This is caused by the output capacitors, which can only be discharged by the load because the power supply cannot sink current.

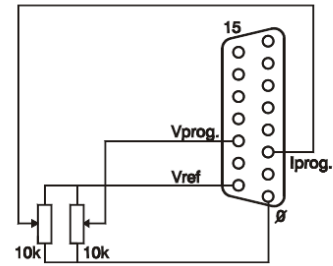

fig 4 - 5 External potmeters.

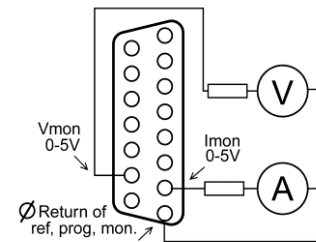

fig 4 - 6 External meters using monitor outputs.

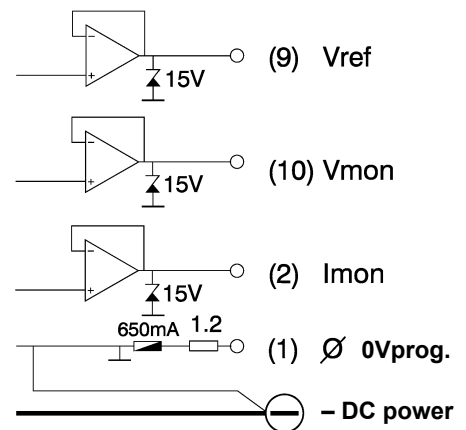

fig 4 - 7 Buffered monitor outputs (internal circuit).

**Warning!** 0Vprog. and Minus DC power are internally connected.

pin	description	pin	description
1	$\emptyset$ , return of reference, prog.inputs and monitor outputs	9	Reference Voltage 5.1 V
2	current monitor output (0 - 5 V)	10	Voltage monitor output (0 - 5 V)
3	current programming input (0 - 5 V)	11	Voltage programming input (0 - 5 V)
4	CC status output, logic 1 = CC mode (5 V / 10 mA)	12	NC
5	Remote Shutdown (+5 V / 1 mA)	13	NC
6	NC	14	NC
7	+12 V output (Ri = 100 Ohm)	15	NC
8	$\emptyset$ , return of status outputs, +12 V and Remote Shutdown		

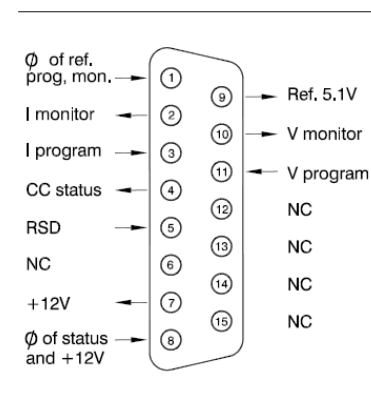

fig 4 - 8 Connections analog programming connector.

#### 4.16 PULSATING LOAD

- To avoid overheating the output capacitors, the AC component of the load current should be limited (fig. 4 - 9).
- One method of decreasing the AC current through the output capacitor is by using a large external electrolytic capacitor in parallel with the load.
- Care must be taken so that the capacitor in combination with the lead inductance will not form a series resonant circuit!

#### 4.17 INSULATION

- For safety the insulation of the separating components (transformers) between input and output is tested at 3750 Vrms during 1 minute. This is tested before assembling.
- Warning! The 3750 Vrms cannot be tested afterwards on the assembled unit because the insulation between the components on the input side to the case (like the bridge rectifier) is specified at 2500 Vrms. Since the insulation output - case is low (only 600 VDC) the insulation of the primary components to case will break down when 3750 Vrms is applied between input and output (2500 Vrms + 600 VDC < 3750 Vrms) (see also fig. 4 - 10).
- Note: when testing the insulation, take care to charge and discharge the capacitors between input - case and output - case slowly (e.g. in one second). This to prevent high peak currents, which could destroy the power supply. Make sure to have discharged the capacitors completely before using it again.

#### 4.18 RFI SUPPRESSION

- Both the input and output have RFI filters, resulting in very low conducted RFI to the line and load. Due to the output filter the output voltage is very clean, having almost no spikes.
- The combination of RFI filters and the closed metal case results in a low radiated RFI.

#### 4.19 OPERATING TEMP

- At full power the operating temperature range is  $-20$  to  $+50$  °C. From 50 to 60 °C the output current has to be derated linearly to 75 % at 60 °C (see fig. 4 - 11). These temperatures hold for normal use.

#### 4.20 THERMAL PROTECTION

- A thermal switch shuts down the output in case of insufficient cooling. After cooling down the unit will start working again.

#### 4.21 HOLD - UP TIME

- The hold - up time depends on the load, output voltage and line input voltage. A lighter load or a lower output voltage, results in a longer hold - up time (see fig. 4 - 12). The influence of the line input voltage is limited because of the active PFC.

#### 4.22 TURN ON DELAY

- The output voltage is available 0.25 sec after mains switch on.

#### 4.23 INRUSH CURRENT

- The inrush current is limited with a 30 Ohm NTC to about 10 A when the NTC is cold.

#### 4.24 COOLING

- The cooling is by natural convection, no noisy blowers are present. The unit should have sufficient free space to let the air flow vertically through the unit. A distance of minimum 5 cm around the unit is recommended.
- For long life the temperature of the air entering the unit, should be below 35 °C under normal conditions.
- Under extreme conditions it should be below 50 °C.

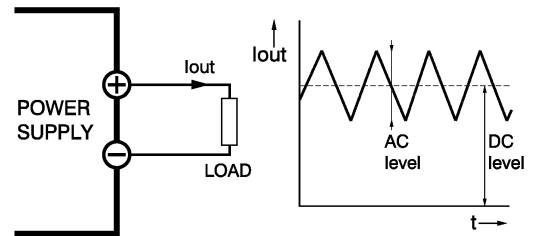

fig 4 - 9  
Pulsating load current.

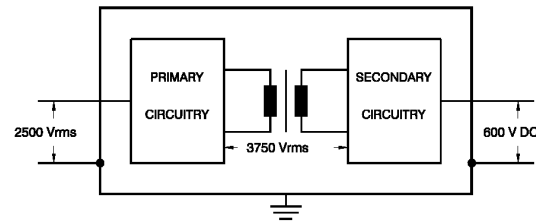

fig 4 - 10  
Insulation test voltages.

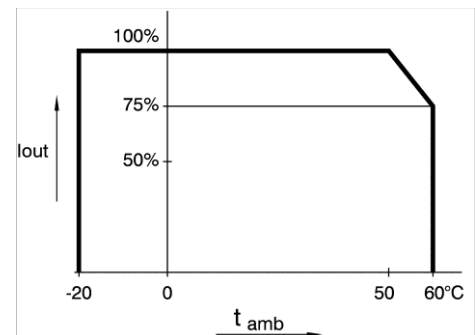

fig 4 - 11  
Operating temperature ranges.

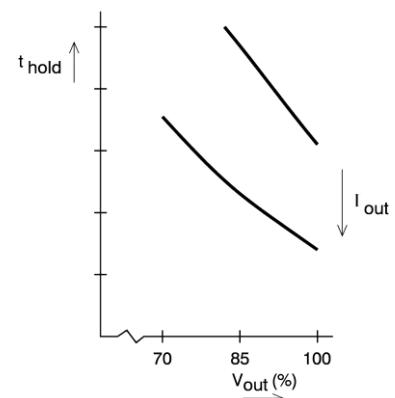

fig 4 - 12  
Hold-up time vs  $V_{out}$  with  $I_{out}$  as a parameter.

**4.25 SERIES OPERATION**

- Series operation is allowed up to 600VDC total voltage. The power supplies can be connected in series without special precautions.

**4.26 PARALLEL OPERATION**

- Paralleling of the units has no limitations. The power supplies can be connected in parallel without special precautions.

**4.27 MASTER / SLAVE OPERATION**

- For easier control, Master / Slave operation is recommended (see fig. 4 - 13 and - 14). The resulting combination behaves like one power supply and can be programmed on the master.
- M/S series operation is allowed up to 600V total voltage.
- The power supplies must be connected with the MASTER / SLAVE SERIES ADAPTER. The master controls one slave, which in its turn controls the second slave and so on. The result is true voltage sharing.
- For M/S parallel operation connections can easily be made on the analog programming connector. The master controls all slaves.
- The result is true current sharing.
- Mixed M/S parallel - series operation is also possible (see fig. 4 - 15).
- Fig. 4 - 16 shows a computer-controlled M/S parallel combination.
- Note: M/S parallel operation is not recommended for more than 4 units, consult factory for a solution.

**4.28 POTENTIOMETERS**

**4.28.1 STANDARD**

- CV and CC potentiometers with knobs at front panel.

**4.28.2 Option P001**

- Screwdriver adjustment for CV and CC at the front panel.

**4.29 Contact & Support**

- For questions about the unit, please contact our support department via the contact form on our website.
- Support: [Contact & Support > Contact Form](#)
- If the unit is defective, first complete the RMA form on our website before returning the unit. Include a detailed fault description to support fast service. Do not attempt to repair the unit yourself.
- RMA form: [Contact & Support > Repair > RMA form](#)

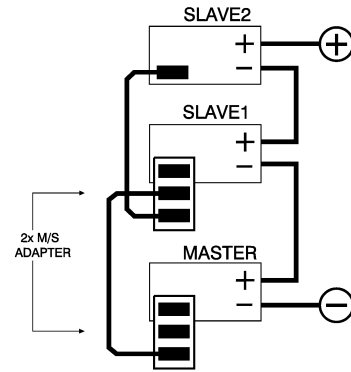

fig 4 - 13  
Master / Slave series operation.

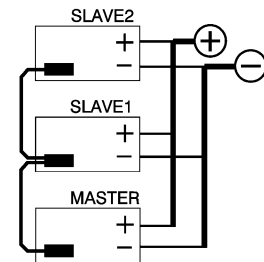

fig 4 - 14  
Master / Slave parallel operation.

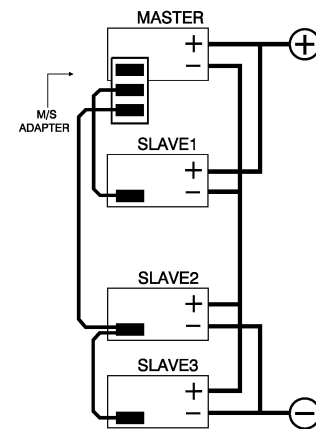

fig 4 - 15  
Master / Slave mixed series-parallel operation.

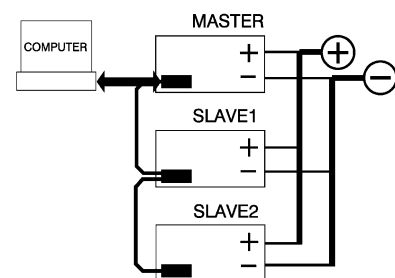

fig 4 - 16  
The Master / Slave combination can also be programmed with the interfaces PSC-ETH or the PSC-232.

## 5 OPERATING

### 5.1 OPERATING THE UNIT FOR THE FIRST TIME

- Check that there is no condensation on the unit. If there is, allow some time to dry.
- Set the program switches on the rear panel on MANUAL (=Factory default).
- Switch on unit.
- Turn both the CV and CC potentiometer a few turns clockwise. A voltage should now be present on the output.

### 5.2 ANALOG PROGRAMMING

- Put the appropriate switch(es) in the position PROGRAM.
- Connect the programming voltage source(s) (0 - 5 V) to the ANALOG PROG. CONNECTOR on the rear panel (see fig. 5 - 1 and - 2). Always use a shielded cable for programming.
- If only the voltage is programmed, the maximum current can still be set with the CC potentiometer and vice versa. If this is not desirable the CC or CV can be set with an external potentiometer, in order to have a fixed setting.
- CAUTION: The analog inputs are not isolated from the output. The Ø of the prog. input (pin 1) is internally connected to the negative output. To protect the internal wiring a 650 mA self-resetting fuse is connected in series (F7\_1) (see fig. 5 - 4).
- For isolated analog programming the ISO AMP MODULE is recommended to avoid earth loops.
- To avoid hum or noise, the programming cable may have to be twisted in some cases.
- To program the unit by current instead of voltage, simply use a parallel resistor as a current to voltage converter.

### 5.3 Ethernet / RS232 PROGRAMMING

- The internal Ethernet interface PSC-ETH and the internal RS232 interface PSC-232 are factory built in.
- Connect the interface with the computer.
- On the power supply set both programming switches in the position program.
- Both CV and CC can be programmed and read back.
- The CC status can also be read by the computer.

### 5.4 MONITORING OUTPUTS

- The 5 V level is compatible with most interfaces.
- Monitoring outputs can drive a meter directly (see fig. 5 - 3).

### 5.5 STATUS OUTPUT

- The status output has a separate Ø connection (pin 8) to avoid unwanted offsets in the programming. This pin is protected with a 650 mA self-resetting fuse (F7\_2).

### 5.6 REMOTE SHUTDOWN

- The remote shutdown can be operated with +5V or a relay contact (see fig. 5 - 5).

### 5.7 MASTER / SLAVE SERIES OPERATION

- For series operation the MASTER / SLAVE SERIES ADAPTER must be used. With this adapter the master can be the upper or lower unit which, in particular for high voltages is an advantage. Other advantages are the fast and easy way of connecting.

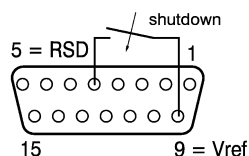

fig 5 - 5  
Remote Shutdown with switch.

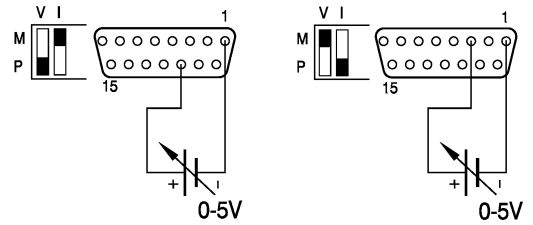

fig 5 - 1  
Programming by voltage  
left voltage-, right current programming.

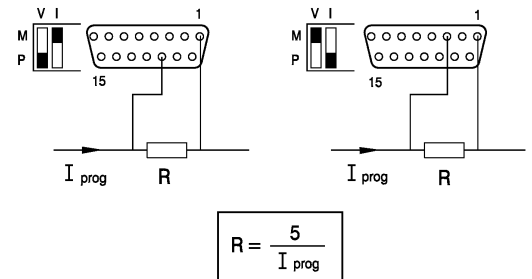

fig 5 - 2  
Programming by current  
left voltage-, right current programming.

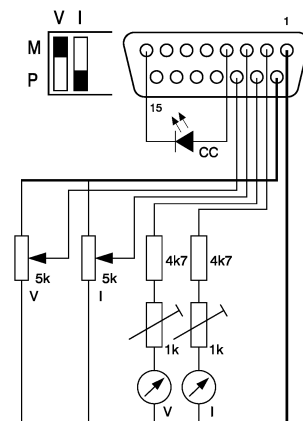

fig 5 - 3  
Remote control.

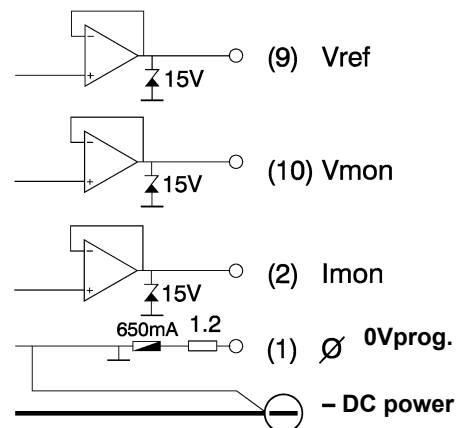

fig 5 - 4  
Internal circuit of programming input and outputs.

**Warning!** 0Vprog. and Minus DC power are internally connected.

- First, connect output terminals and test system in normal series operation. Ensure that all (output) power connections are reliable.
- Second, switch off all units. Connect units as shown in fig. 5 - 6. Use standard 15 pole (1:1) shielded cables. Both prog. switches of the slave(s) should be in the position PROGRAM.
- The max. number of slaves is only limited by the max. total voltage of 600 V.

**5.8 MASTER / SLAVE PARALLEL OPERATION**

- Note: Master / Slave parallel is not recommended for more than 4 units, consult factory for using more than 4 power supplies in parallel.
- First connect output terminals and test system in normal parallel operation. Ensure that all power connections are reliable. An interruption of one of the (output) power leads can cause a fuse to blow in the unit, see next chapter "trouble shooting".
- Second, switch off all units. Plug in prog. connectors with the connections according to fig. 5 - 7 (bus bar topology). Always use a shielded cable. The shielding must be connected to the case of the supply. Both prog. switches of the slaves should be in the position PROGRAM.
- The purpose of the link between pin 9 and 11 is to set the voltage limit of the slaves at maximum.
- Keep the load close to the master. Keep wiring between master and slaves short. The voltage drop between a unit and the buss bar should be kept < 10mV.
- Accidental interruption of a negative load lead of a unit during operation will cause fuse F7\_1 to blow, see section 'trouble shooting'.

**5.9 OPERATING AND STORAGE CONDITIONS**

**5.9.1 TEMPERATURE**

- The operating temperature range at full load is -20 to +50 °C.
- Please note: a lower temperature extends the life of the power supply.
- The storage temperature range is -40 to +70 °C.

**5.9.2 HUMIDITY**

- During normal operation humidity will not harm the power supply, provided the air is not aggressive.
- The heat normally produced in the power supply will keep it dry.
- Condensation. Avoid condensation inside the power supply, break-down could be the result. Condensation can occur during a period the power supply is switched off (or operating at no load) and the ambient temperature is increasing.
- Always allow the power supply to dry before switching it on again.

**5.9.3 GALVANIC INDUSTRY**

- For using the power supplies in the galvanic industry, it is strongly recommended to take precautions against an aggressive environment.
- An aggressive environment with acid, salt, etc. can harm the electronic components. Sometimes even the copper traces of the pc-boards dissolve.
- To avoid problems the power supplies should be mounted in a relative clean room or mounted in a cabinet receiving clean air with over pressure. Or in a cabinet with a heat exchanger.

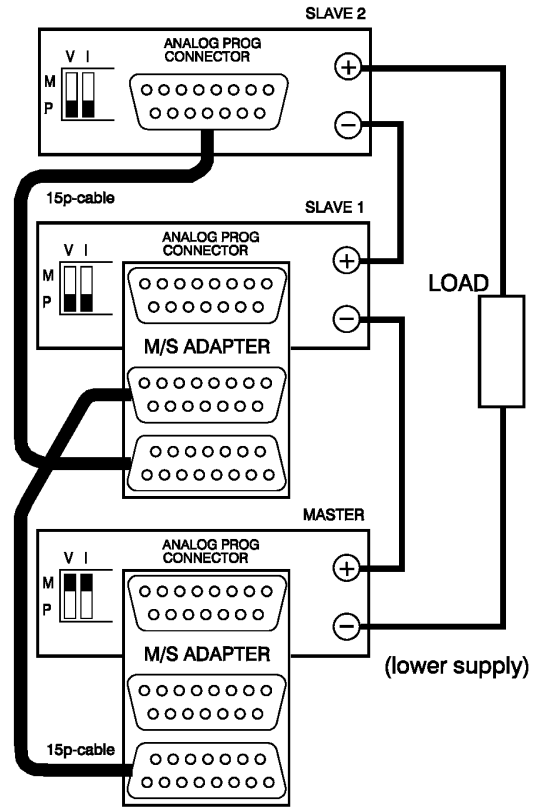

fig 5 - 6  
Master / Slave series connection with two MS SERIES ADAPTERS.

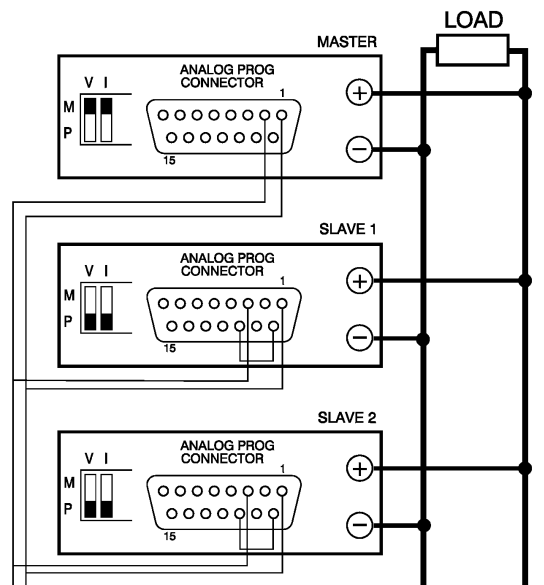

fig 5 - 7  
Master / Slave parallel connections.

## 6 MAINTENANCE & TROUBLE SHOOTING

### 6.1 GENERAL

- The ES-series power supplies normally need no maintenance or calibration. Only care must be taken that the cooling of the unit is not obstructed.

### 6.2 NO OUTPUT (normal operation)

- Remove load from output.
- Check position of prog. switches at the rear panel, they should be on MANUAL.
- Switch on unit.
- Turn both the CV and CC potentiometer a few turns clockwise. A voltage should be present on the output.

### 6.3 PROGRAMMING DOES NOT WORK OK

- Check position of prog. switches at rear panel.
- The unit works OK in manual control, but in programming mode the output voltage / current has a large error.
- Probably the fuse in series with Ø (pin 1) of prog. connector tripped, the fuse (F7\_1 = 650 mA) is a self-resetting type.
- To check the fuse (F7\_1) measure the voltage between Ø and the minus output, during the fault condition. The voltage should only be a few mV, a high voltage means that an unwanted current is flowing through pin 1 of the prog. connector.
- Please check why current is flowing through pin 1 (see also next paragraph and fig. 6 - 1).

### 6.4 PROGRAMMING OFFSETS

- Unwanted offsets in the programming can be caused by earth loops.
- Fig. 6 - 1 shows a typical earthing problem. In case the load has a connection to earth and the programming source as well, problems could occur. Improper choice of the earthing point of the load can give a voltage drop of  $\Delta V1$ .
- Connecting the minus or zero to a separate earth connection can give a voltage drop of  $\Delta V2$ . Because the internal wires of the programming input are thin, the voltage drops  $\Delta V1$  and  $\Delta V2$  will be across the internal wiring as well. Resulting in a error voltage in series with the programming voltage.
- The best solution for this is using a floating programming source with the help of the ISO AMP MODULE or a floating load.

### 6.5 STATUS OUTPUT FAILS

- Check fuse F7\_2 in series with Ø (pin 8 of programming connector). To check the fuse measure the voltage between Ø and the minus DC Power output, a high voltage means too much current is flowing through the fuse. F7\_2 = 650 mA - self resetting.

### 6.6 MASTER / SLAVE PARALLEL PROBLEMS

- Accidental interruption of a minus lead of a unit during operation will cause fuse F7\_1 to blow. To check the fuse, measure the voltage between Ø (pin 1 of prog. conn.) and the minus DC power output, the fuse is a self-resetting type. F7\_1 = 650 mA self-resetting. If the voltage is too high, too much current is flowing through it.
- Check link between pin 9 and 11 on the programming connector of the slaves.

### 6.7 NO LEDS on.

- Overheating can be the cause, cooling down will reset the thermal protection.
- Check input power.
- Check fuses inside unit.

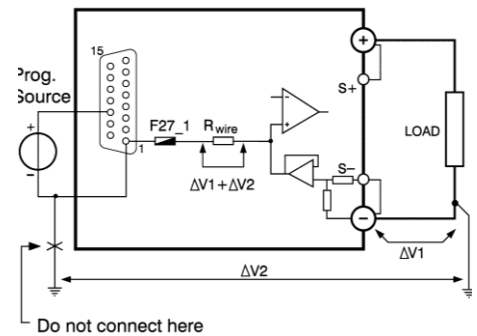

fig 6 - 1  
Unwanted programming offsets.

**Warning!** 0Vprog. and Minus DC power are internally connected.

## 7 OPTIONS

### 7.1 REMOTE SENSING

#### 7.1.1 DESCRIPTIONS

- The voltage at the load can be kept constant by remote sensing. This feature is not recommended for normal use but only when the load voltage is not allowed to vary more than a few millivolts. Always use a shielded cable for sensing.
- In order to compensate for the voltage drop across the load leads, the unit will have to supply a higher voltage:  $U_{out} = (\text{voltage drop across each lead}) + (\text{voltage across the load})$  (see fig. 7 - 2).
- The voltage display is connected to the sense leads and therefore reads the voltage across the load and not the voltage on the output terminals.
- The sense leads are protected for accidental interruption, in which case the output voltage will go to a max. of 115% of the set value.

#### 7.1.2 PULSATING LOAD

- When using remote sensing on a pulsating load (for instance a DC-motor), use a capacitor between S+ and + and between S- and - and a series resistor in the sense leads (see fig. 7 - 3). Like this the AC-component caused by the voltage drop across the load leads, is filtered.

#### 7.1.3 OPERATING

- Remove the links on the TERMINAL BLOCK (on rear panel) and connect sense leads (thin shielded measuring wires) to S+ and S- (see fig. 7 - 4).
- With remote sensing the voltage on the load can be kept constant. The voltage drop across the load leads will be compensated. This feature is not recommended for normal use, because it can easily give problems.
- Max. 2 V per load lead can be compensated. Note that the voltage drop in the leads decreases the max. output voltage rating. In fig. 7 - 2 it can be seen that on a 15 V power supply only 11 V will be available on the load when 2x 2 V compensation is used.
- In order to prevent interference it is advisable to use shielded cable for the sense leads. The inductance of the loads leads could give a problem with pulsating loads. In this case a large electrolytic capacitor in parallel with the load will help. Check that the capacitor in combination with the load leads does not form a resonant circuit resulting in a large AC current flowing in the leads.
- Since the voltage display is internally connected to the sensing terminals, it will automatically indicate the voltage on the load. Note that the voltage measured on the load will be lower than on the output terminals.

#### 7.1.4 MASTER / SLAVE PARALLEL OPERATION WITH SENSE OPTIONS

- Disconnect the links between the S- and - of the slaves only. If not removed the current sharing will not be proportional.
- The S- and S+ could be connected to the load if desired, but this is not recommended because of the complexity.

#### 7.1.5 TROUBLE SHOOTING

- NO OUTPUT (normal operation)
- Check the connections on the TERMINAL BLOCK
- (at rear panel), there should be a link between + and S+ and between - and S- (see fig. 7 - 4).
- MASTER / SLAVE PARALLEL PROBLEMS
- Current sharing is not ok. Probably the links between S- and - of the slaves are not removed.



fig 7 - 1

With the REMOTE SENSING options, the power connectors are moved to the rear panel.

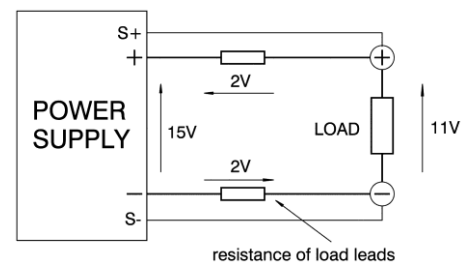

fig 7 - 2

With remote sensing the voltage drop in the load subtracts from the maximum output.

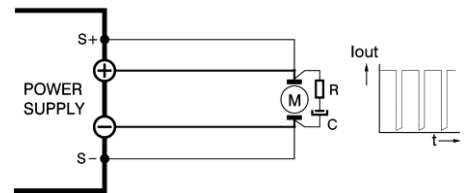

fig 7 - 3

Remote sensing on a pulsating load.

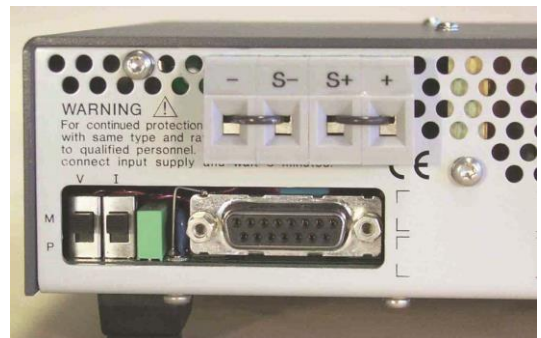

fig 7 - 4

On the terminal block, the +, S+, - and S- wires must be connected. When using the power supply without sensing, the links between + and S+, and between - and S- must be inserted.

- OUTPUT VOLTAGE IS HIGHER THAN SET VALUE
- Check connections on TERMINAL BLOCK (on rear panel),  
For normal operation there should be a link between + and S+  
and between – and S– (see also fig. 7 - 4).
- When remote sensing is used, check the wires of the sensing.

### 7.2 BUILT IN PSC-232 for the ES 150 - series

- OPTION P148
- For this option the RS232 Controller PSC-232 has been built inside the unit.
- With the PSC-232 the voltage and current can easily be programmed and read back.
- Also all the status outputs can be read by the computer.
- See PSC-232 manual for further details.

### 7.3 BUILT IN PSC-ETH for the ES 150 - series

- OPTION P150
- For this option the Ethernet Controller PSC-ETH has been built inside the unit.
- With the PSC-ETH the voltage and current can easily be programmed and read back.
- Also all the status outputs can be read by the computer.  
See PSC-ETH manual for further details.

### 7.4 LOW OVL SETTING for the ES 75-2

- OPTION P173
- For this option the Over Voltage Limit (OVL) has been set below 60 V.

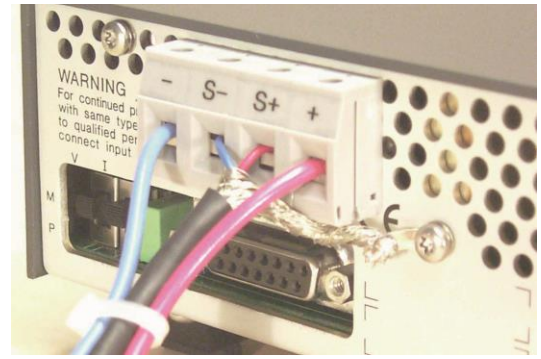

fig 7 – 5

*The shielding of the sense wires must be connected to the case of the power supply.*



## 8 EU Declaration of Conformity - ES150-series



We

Delta Elektronika  
Vissersdijk 4  
4301 ND Zierikzee  
The Netherlands

Declare under sole responsibility that the following Power Supplies:

**ES015-10**  
**ES030-5**  
**ES075-2**  
**ES0300-0.45**

Meet the intent of Directives

2014/30/EU Electromagnetic Compatibility (EMC)  
2014/35/EU Low Voltage Directive (LVD)  
2011/65/EU Reduction of Hazardous Substances (RoHS2)

Compliance was demonstrated to the following specification as listed in the official Journal of the European Union:

**EN 61326-1:2013**

**EMC requirements for electrical equipment for measurement, control and laboratory use**

**EN 61010-1:2010/A1:2019/AC:2019-04**

**Safety requirements for electrical equipment for measurement, control and laboratory use**

**EN IEC 63000:2018**

**Assessment of electrical and electronic products with respect to RoHS**

J. Koopman  
Managing director,  
Zierikzee, April 2025