



PRODUCT MANUAL

External Anybus® Carrier Interface

Firmware Update

It is strongly recommended to first perform an interface firmware update before further operation. Detailed instructions are provided in Chapter 8 of this manual.

Driver & Example Software

Drivers and example projects for a range of applications and interfaces can be downloaded from our website. [Products/Interfaces/Downloads](#)

CONTENTS

1	Information on this document	4
1.1	Validity	4
1.2	Target Group	4
1.3	Trademarks	4
1.4	Content and Structure	4
1.5	Additional information	4
1.6	Contact	4
2	General	5
2.1	Introduction	5
2.2	Safety Instructions	5
2.3	Symbols & Markings	5
2.4	Box Contents	5
2.5	References	6
2.6	System LEDs	6
2.7	Analog Interface Pinout	7
2.8	Analog Resolution	7
2.9	Insert Firmware Version	7
3	Setup and Configuration	8
3.1	Connections	8
3.2	Console and SCPI Terminal	8
3.3	Configure Anybus insert Settings	10
4	Power Supply Programming	13
4.1	Ethernet-based Fieldbus	13
4.2	Serial-based Fieldbus	13
4.3	Serial Control: Console Mode	14
4.4	Serial Control: SCPI Mode	14
5	Fieldbus Implementation	14
6	Resetting	15
6.1	Factory Default Settings	15
7	Calibration	16
7.1	Calibrating Voltage	16
7.2	Calibrating Current	17
7.3	Calibration Adjust	18
8	Firmware Updating	19
9	Troubleshooting	19
9.1	LED Statuses	19
9.2	Console	20
9.3	Programming and Monitoring	20
10	SCPI Implementation	21
10.1	SCPI Conventions	21
10.2	Syntax	21
10.3	Query	21
10.4	Space <sp>	21
10.5	Terminator <term>	21
10.6	Parameters	21

10.7	General Instructions.....	22
10.8	Source Subsystem.....	23
10.9	Measure Subsystem.....	24
10.10	Calibrate Subsystem.....	24
10.11	System Subsystem.....	26
11	SCPI-Command List.....	29
12	EU Declaration of Conformity – PSC-ANY-EXT.....	31

1 Information on this document

1.1 Validity

This document is valid for the following products:

- PSC-ANY-EXT (External Anybus carrier interface unit)
 - With firmware version as stated on the cover or higher.

1.2 Target Group

This equipment must be operated only by qualified personnel who understand the instructions and safety instructions provided with the equipment. If the equipment must be operated by unqualified personnel, then he/she must be supervised by qualified personnel.

1.3 Trademarks

Anybus® is a registered trademark of HMS Industrial Networks AB. All other trademarks mentioned in this document are the property of their respective holders.

1.4 Content and Structure

Please consider the safety instructions of all products involved before operating or connecting. This product manual introduces the PSC-ANY-EXT interfacing unit and explains how it can be used. The manual starts with an introduction to the device, followed by safety instructions, which should be consulted before connecting anything to the device. The second part of the manual covers the setup and configuration of the PSC-ANY and Anybus insert. The configuration chapter is followed by a chapter that explains the programming and monitoring of a power supply using the PSC-ANY. The remaining chapters address secondary operations such as calibration, resetting, firmware updating, troubleshooting and a listing of available SCPI commands. Supplementary materials such as fieldbus implementation guides, programming examples and device description files are listed in Section 1.5.

1.5 Additional information

The following additional product related documentation is available on our website. Please visit the website to find a list of the latest supplementary materials.

PSC-ANY-EXT: [Products > Interfaces > Anybus unit \(external\) > Downloads](#)

The PSC-ANY-EXT only supports Data Format A.

Document name	Product	Type
Anybus Fieldbus Implementation Guide	PSC-ANY-EXT	Guide
Python Example Code PSC-ANY-EXT	PSC-ANY-EXT	Software
Firmware Updater PSC-ANY-EXT	PSC-ANY-EXT	Software
EtherCAT Anybus insert detection Python script	PSC-ANY-EXT	Software
Device description files Data Format A <ul style="list-style-type: none"> • CANopen EDS Data Format A • EtherCAT ESI Data Format A • Ethernet/IP EDS Data Format A • PROFIBUS GSD Data Format A • PROFINET GSDML Data Format A 	PSC-ANY-EXT	Configuration files

Please consult the website for the latest document versions and additional information.

1.6 Contact

For additional guidance, questions, or feedback, please use the contact form on our website. A structured technical contact form is available for submitting detailed descriptions and uploading files.

In case of malfunction or breakdown, please use the RMA form to arrange service for your product.

Technical inquiries: [Contact & Support > Contact form](#)

Service & repairs: [Contact & Support > Repair service > RMA form](#)

2 General

2.1 Introduction

The PSC-ANY-EXT is an interface unit that can be used to extend the programming capabilities of power supplies with an analog programming interface. The interface's main function is to convert analog programming and monitoring signals to a supported Anybus Compactcom M40 insert of choice. Each of these pluggable inserts enables programming and monitoring of a power supply through a different communication protocol.

The Anybus M40 inserts are pluggable and can be inserted into the rear side of the PSC-ANY unit. The unit itself and the Anybus insert are configured through a USB interface located at the rear side of the unit. A secondary and independent function to the Anybus insert's fieldbus is the possibility of serial programming and monitoring of a power supply using SCPI over the USB interface. The front and rear side of the PSC-ANY are shown in Figure 2.1.



Figure 2.1: Front and rear side of the PSC-ANY

The currently supported Anybus M40 inserts are: EtherCAT, EtherNet/IP, ModbusTCP, PROFINET, CANopen and PROFIBUS.

Note that the PSC-ANY-EXT is only compatible with power supplies that have an analog connector or INT-MOD-ANA interface installed.

2.2 Safety Instructions

The following safety precautions must be observed during all phases of operation, service and repair of this equipment. Failure to comply with the safety precautions or warnings in this document violates safety standards of design, manufacture and intended use of this equipment and may impair the built-in protections. Delta Elektronika shall not be liable for user's failure to comply with these requirements.

2.2.1 Installation Category

The Delta Elektronika interfaces have been evaluated to installation category II (Over voltage category II).

2.2.2 Removal of Unit Covers & Modifications

Operating personnel should not remove covers other than the Anybus cover. No internal adjustment or component replacement is allowed by non-Delta Elektronika qualified personnel.

2.2.3 Parts Substitutions & Modifications

Parts substitutions and modifications are allowed by authorized Delta Elektronika service personnel only. For repairs the unit must be returned to a Delta Elektronika service facility.

2.2.4 Cabling

The included power cord, straight through DB15 cable and USB cable must be used for proper functionality. Use of a different cable, such as a longer USB cable, is at the user's own risk.

2.2.5 Environmental Conditions

The Delta Elektronika PSC-ANY-EXT safety approval applies to the following operating conditions:

- Usage: Indoor use only.
- **Warning!** Not intended to be used in the presence of children or animals!
- Ambient temperature: -20 to 50 °C.
- Maximum relative humidity: 95%, non-condensing, up to 40 °C, 75%, non-condensing, up to 50 °C.
- Altitude: Do not use above 2000 m sea level.
- **Warning!** Electrical Creepage & Clearance not valid for higher altitudes!
- Pollution degree: 2

2.3 Symbols & Markings

Instruction manual symbol. The instrument will be marked with this symbol when it is necessary for the user to refer to the instruction manual.



Off (supply).



On (supply).



This marking shown on the product, its packing or its literature indicates that it should not be disposed with other wastes at the end of its working life, but should be collected separately to recycle it responsibly to promote the sustainable reuse of material resources.

2.4 Box Contents

- The box will contain the following content:
- 1x PSC-ANY-EXT
- 1x AC Power Cord
- 1x USB Cable
- 1x Straight Through DB15 Cable
- 1x DIN-Rail Clip

The PSC-ANY can optionally be mounted in a 19-inch front plate rack adapter. The PSC-ANY is mounted using the screw holes at the front of the unit. The adapter plates can be ordered separately, please contact our sales department for more information.

The DIN-rail clip can be used to mount the PSC-ANY to a DIN-rail. This is done using two of the available screw holes at the side of the PSC-ANY unit.

Note: Anybus inserts from HMS are not included. These inserts need to be bought separately on www.DeltaPowerSupplies.com. Navigate to "Products > Interfaces > Anybus unit (external) > Options" to buy the desired fieldbus inserts.

2.5 References

The following references are used throughout the manual:

- | | |
|--------------------|-----------------------|
| Objects: | Interfaces: |
| (1): PC | (A): Fieldbus |
| (2): PSC-ANY-EXT | (B): USB (Console) |
| (3): Power supply | (E): Analog Interface |
| (4): Anybus Insert | |

Figure 2.2 to Figure 2.4 , illustrate each object corresponding to a reference and Figure 2.3 shows the connections between the objects

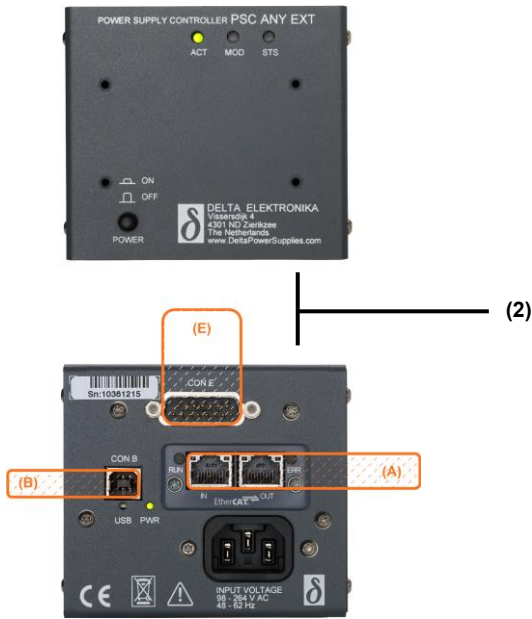

Figure 2.2: PSC-ANY-EXT, front and rear side



Figure 2.5: Delta Elektronika power supply.

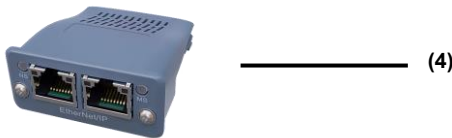

Figure 2.4: Anybus Compactcom M40 module

2.6 System LEDs

The PSC-ANY-EXT has three LEDs on the front and two on the back, each representing a specific status. These LEDs can be seen in Figure 2.2. The front side LEDs are designated as ACT, MOD and STS. The rear side LEDs are designated as USB and PWR. The meaning of each LED-state is explained in Table 2.1.

LED designator descriptions:

- ACT: PSC-ANY (Activity) status
- MOD: Anybus Insert status
- STS: Power supply status
- PWR: Power status of PSC-ANY
- USB: USB status

LED	State	Description
ACT	Off	Software does not boot.
	Green	Normal operation.
	Green (Blinking)	PSC-ANY-EXT CTRL MUX is set to console/SCPI.
	Red (Blinking)	Error in PSC-ANY-EXT.
MOD	Off	No Anybus insert inserted.
	Green	Anybus driver started, and Anybus insert detected.
	Red	Anybus driver did not start, or insert not supported.
	Red (Blinking)	Anybus insert or driver error.
STS	Off	No power supply connected.
	Green	Power supply connected.
	Red	Power supply is in RSD.
	Red (Blinking)	AC-Fail, power sink overload (PSOL) or over-temperature (OT) is active.
ACT+MOD+STS	Green (Blinking)	No power supply, Anybus insert, and USB connected.
PWR	Off	PSC-ANY-EXT not powered.
	Green	PSC-ANY-EXT powered.
USB	Off	USB not connected.
	Green	USB connected.
	Orange	PSC-ANY-EXT firmware update in progress.

Table 2.1: Status LEDs of PSC-ANY unit

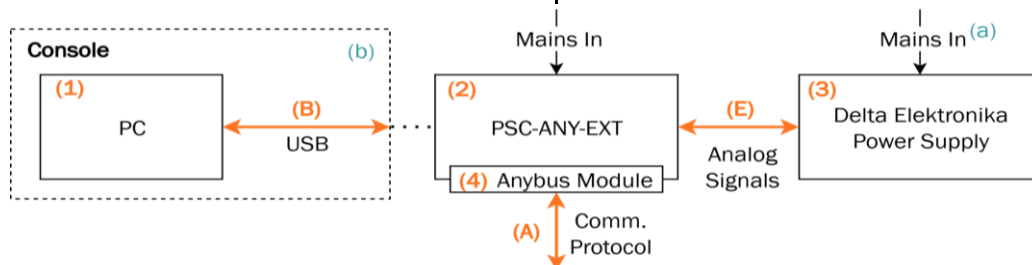

Figure 2.3: Interfacing of the PSC-ANY-EXT with its surroundings.

2.7 Analog Interface Pinout

All the signals present on CON E of the Delta Elektronika power supply can be read and/or written using the PSC-ANY-EXT in combination with the desired fieldbus through an Anybus insert or USB interface. The power supply (or INT-MOD-ANA) being used may not support all the signals shown in Figure 2.7. For more information about the available signals, see the manual of the specific Delta Elektronika power supply.

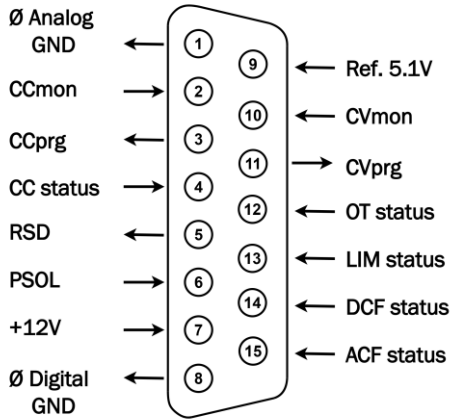

Figure 2.7: CON E: Connection diagram.

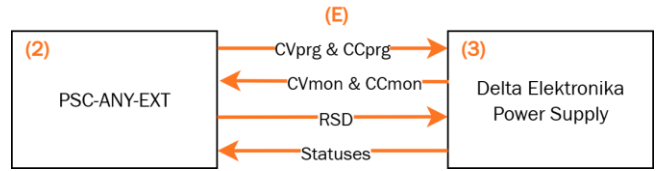

Figure 2.6: CON E: Signal interfacing

2.8 Analog Resolution

The power supplies of Delta Elektronika are remarkably stable and accurate. With its 16-bit programming and measuring resolution, the PSC-ANY-EXT is designed especially for these kinds of power supplies. To calculate the step size in voltage or current, use the equation below:

$$stepsize (CVprg, CCprg, CVmon) = \frac{MaximumOutput}{2^{16}}$$

$$stepsize (CCmon) = \frac{MaximumOutput}{2^{15}}$$

2.9 Anybus Insert Firmware Version

The Anybus insert firmware versions seen in Table 2.2 are the minimum firmware versions that are supported to be used with the PSC-ANY-EXT. No support is given to older versions, although they may still function as expected. Newer insert versions are supported.

It is possible to determine the firmware version of the Anybus insert through the PSC-ANY 's info panel which will be discussed later on in this manual.

Anybus M40 Insert	PROFIBUS	PROFINET-IRT	Ethernet/IP	EtherCAT	Modbus-TCP	CANopen
Supported Firmware	1.15.1 +	1.59.1 +	1.59.2 +	2.23.1 +	1.16.1 +	1.2.1 +

Table 2.2: Minimum firmware version supported Anybus inserts

3 Setup and Configuration

This chapter explains how to set up and configure the PSC-ANY-EXT and if inserted, the Anybus insert.

The PSC-ANY and Anybus insert can be configured through the USB interface on the PSC-ANY. The configuration can be performed through a console in a terminal session or through SCPI commands. The easiest way to start is to use the built-in console. For automated configuration, the SCPI command approach is better suited. Each of these approaches is explained in this chapter, Chapter 3.

The power supply connected to the PSC-ANY can be programmed and monitored through the Anybus insert or through the USB interface of the PSC-ANY, using SCPI commands or manual operation through the console. The best programming and monitoring performance is achieved when using the field bus instead of the console or SCPI terminal. These methods will be explained in Chapter 4.

If problems arise, please consult Chapter 9 for troubleshooting.

This chapter will start with the physical connections in Section 3.1 and will then start with opening the console. Optionally followed by an SCPI terminal session in Section 3.2.

3.1 Connections

In this paragraph, the required hardware will be set-up. See section 2.5 for the object references used.

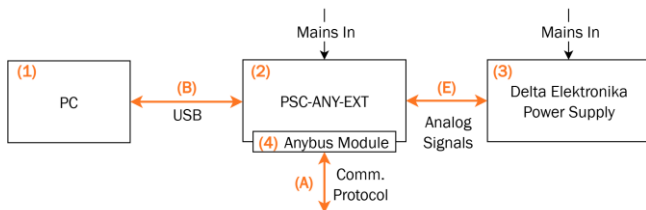

Figure 3.1: Setup used throughout Chapter 3

3.1.1 Plugging in the Anybus Insert

If the PSC-ANY will be used with an Anybus insert, it should be inserted at this point, see Figure 2.2 for an overview.

Make sure that the housing of the Anybus insert is flush with the PSC-ANY-EXT and that the screws are fully fastened. The screws should be fastened with a TORX-8 screwdriver. The recommended tightening torque is 0.25 Nm.

Note: The Anybus inserts are not hot-swappable.

3.1.2 Set Power Supply Programming Source

To program and monitor the power supply using the PSC-ANY, the programming source of the power supply should be set to the analog interface. Please consult the product manual of the power supply used to set the programming source.

3.1.3 Connecting the PSC and Power Supply

The following steps should be performed:

1. Connect (2) to mains using the power cord included.
2. Connect (3) to mains using the power cord required for the power supply being used.
3. Connect (2) to (3) using the supplied DB15 cable.
4. If an Anybus insert is used, plug the desired (4) into (2).
5. If an Anybus insert will be used, make sure (4) sits tight and is flush with the PSC-ANY-EXT.

6. If an Anybus insert is used, Fasten the screws of (4).

7. Turn on (3).

8. Turn on (2) using the power button. Make sure the 'PWR' LED and 'ACT' LED are lit.

Note that the mains operating range of the PSC-ANY-EXT is between 98 V_{AC} and 264 V_{AC}.

3.2 Console and SCPI Terminal

This paragraph will go through the process of opening the PSC-ANY-EXT console and SCPI terminal over the USB connection. They can both be used to configure the communication bus, control the power supply, view the error history, calibrating and resetting the PSC-ANY-EXT. During these instructions the PuTTY application is used for demonstration.

The PSC-ANY can only be in either the console or SCPI terminal mode. This mode is changed in the PSC-ANY settings. Factory default is console mode.

Note that settings configured in the console will be reset on a power cycle unless they are saved.

3.2.1 Opening the Console

To open the console of the PSC-ANY, follow the steps below.

1. Use the setup explained in Section 3.1.1. Make sure that the PSC-ANY-EXT is turned off.
2. Make sure the latest serial drivers are installed on the PC. They can be [downloaded here](#). Install the version called 'CP210x VCP Windows'.
3. Connect (1) to (2) using the supplied USB cable that is capable of transmitting data.
4. Open "Device Manager" on the PC to see which COM-port is being occupied by the PSC-ANY-EXT (Figure 3.2).

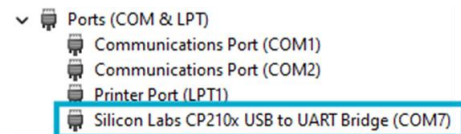

Figure 3.2: Device manager

5. Open a terminal capable of communicating over serial. The PuTTY application is recommended and used in this example. PuTTY can be downloaded on both Windows (download) and Linux (sudo apt-get install putty).
6. Navigate to 'Session' > 'Connection type' and select 'Serial'
7. Navigate to 'Connection > Serial', and copy the communication settings seen in Figure 3.3 into PuTTY. Use the acquired COM-port.

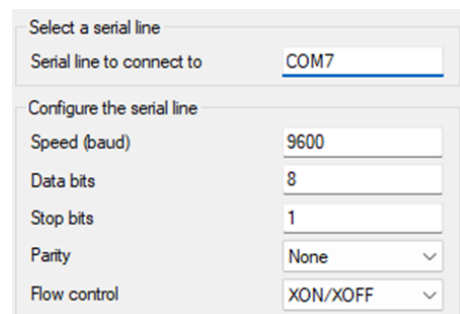

Figure 3.3: PuTTY: connection>serial

8. Navigate to 'Terminal' and copy the terminal settings seen in Figure 3.4.

9. Press “Open” in the lower right corner to start the communication.
10. Turn on the PSC-ANY-EXT.

The terminal will fill with text, showing the ‘First Time Setup.’ If not, start over again. If the terminal opens but not characters are shown (incorrect sequence of instructions by the user), a possible way to enter the main menu is by pressing the escape button on the keyboard.

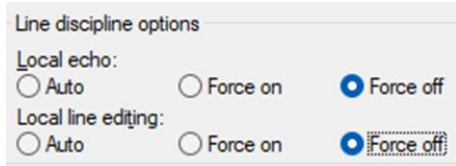

Figure 3.4: PuTTY: local line editing

Be aware

The ‘MOD’ LED is solid red until the rated output voltage and current of the power supply is set in the console.

The ‘ACT’, ‘MOD’ and ‘STS’ LEDs will blink green if no power supply, Anybus insert and USB is connected.

Within the console, execute the following steps:

11. Enter the rated voltage [V] of the used power supply followed by **<ENTER>**.

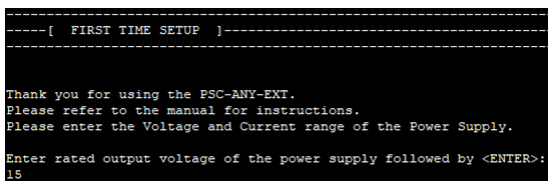

12. Enter the rated current [A] of the used power supply followed by **<ENTER>**.

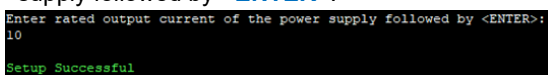

The console should now be open.

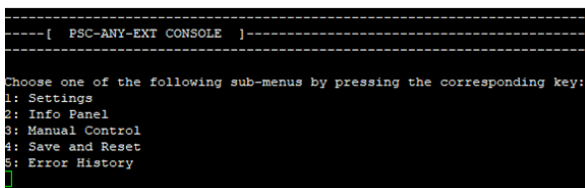

13. Press **<4>** to enter **Save and Reset**.

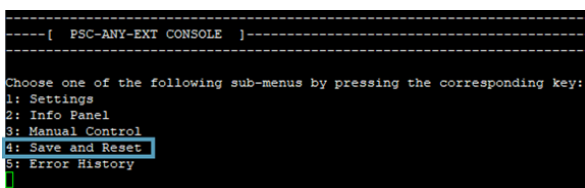

14. Press **<1>** and type the default password “**depower<ENTER>**” to **Save Settings**. The password is case insensitive.

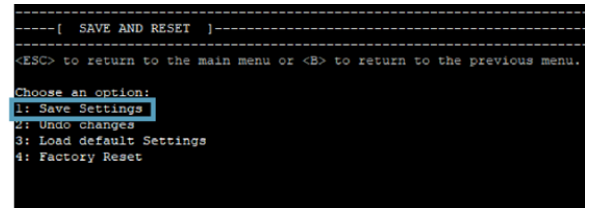

Be aware

When changing the type of power supply connected to the unit, the power supply settings in the console must be adjusted accordingly. To do this, go to **<1> Settings ▶<2> Power Supply Settings ▶<3> Power Supply Model**, and update the voltage and current ranges.

To change the Anybus insert’s settings using the previously opened console, jump to Section 3.3.

Continue with Sections 3.2.2 and 3.2.2 to open a SCPI terminal and to revert to console mode.

3.2.2 Opening the SCPI Terminal

Be aware that the change to SCPI terminal is immediate after step 4 and that backspace is not available in the SCPI-terminal. See Section 3.2.3 to go from SCPI terminal to the console.

1. Open the console as explained in 3.2.1. In the console, open the menu **Settings** by pressing **<1>**

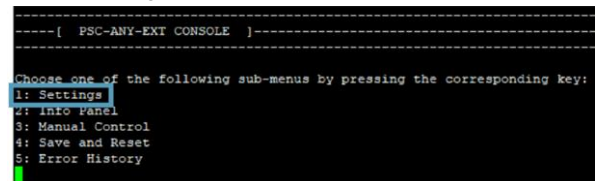

2. Open the menu **Console Settings** by pressing **<3>**

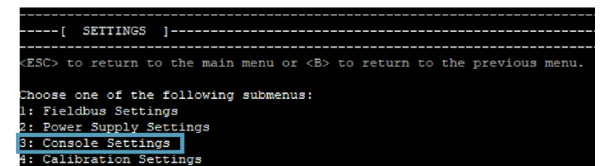

3. Open **Switch to SCPI Terminal** by pressing **<2>** and typing **Yes<ENTER>**.

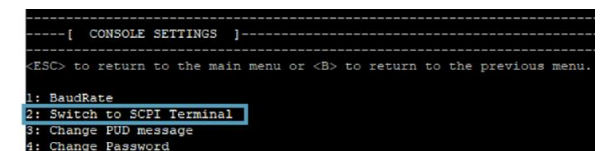

4. Reopen the preferred serial terminal in the PuTTY application.
5. Use the same settings as used in 3.2.1 but make sure to set “Local echo” to “Force on” and enable “Implicit CR in every LF” and “Implicit LF in every CR” to increase readability.

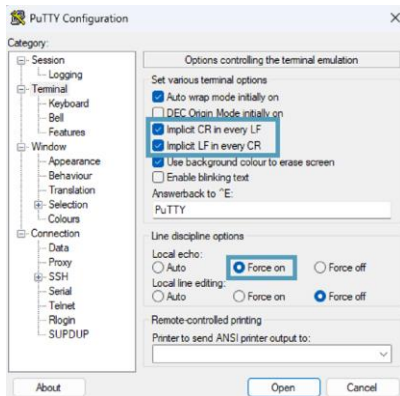

6. In the SCPI-terminal, type ***IDN?** and press **<ENTER>** To request the ID of the PSC-ANY-EXT.

```
*IDN?
DELTA ELEKTRONIKA BV,PSC ANY EXT V00.09,000012345678,0
```

7. Type ***SAV<sp><password>** and press **<ENTER>** to save changes. By default, the password is "depower". Refer to Chapter 10 for all available SCPI-commands.

```
*SAV depower
```

3.2.3 Switch From SCPI Terminal to Console

Note that this paragraph is not mandatory to get started with the fieldbus.

1. Open a serial terminal as explained in Section 3.2.1. However, make sure to set "Local echo" to "Force on" and enable "Implicit CR in every LF" and "Implicit LF in every CR" to increase readability.

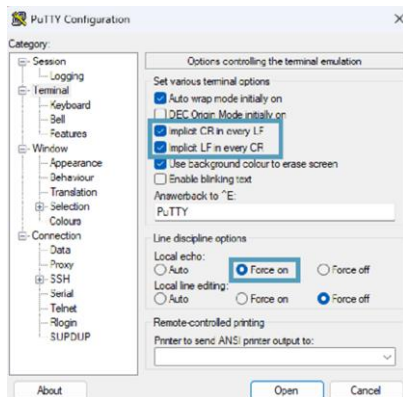

2. To make sure that you are indeed in the SCPI-terminal, type ***IDN?** and press **<ENTER>** to request the ID of the PSC-ANY-EXT. The result should be in the following format:

```
Input: '*IDN?'
DELTA ELEKTRONIKA BV,PSC ANY EXT 0095,,0
```

3. In the SCPI-terminal, type **SYSTEM:COMMunicate:CONsole** and press **<ENTER>** to switch from SCPI terminal to the console.

```
system:communicate:console
```

4. The console should now be open.

```
----- [ PSC-ANY-EXT CONSOLE ] -----
Choose one of the following sub-menus by pressing the corresponding key:
1: Settings
2: Info Panel
3: Manual Control
4: Save and Reset
5: Error History
```

5. Press **<4>** to enter **Save and Reset**

```
----- [ SAVE AND RESET ] -----
<ESC> to return to the main menu or <B> to return to the previous menu.
Choose an option:
1: Save Settings
2: Undo changes
3: Load default Settings
4: Factory Reset
```

6. Press **<1>** and type the password (default: "depower<ENTER>") to **Save Settings**. The password is case insensitive.

```
----- [ PSC-ANY-EXT CONSOLE ] -----
Choose one of the following sub-menus by pressing the corresponding key:
1: Settings
2: Info Panel
3: Manual Control
4: Save and Reset
5: Error History
```

3.3 Configure Anybus Insert Settings

Now that the console is open, it is possible to configure the Anybus insert settings. These settings are not needed when programming and monitoring is solely performed through SCPI commands over the USB interface of the PSC-ANY. If so, please jump to Chapter 4 for further instructions about programming and monitoring through the USB interface.

The Anybus insert settings consist of the fieldbus settings in Section 3.3.1 and data format settings in Section 3.3.2.

3.3.1 Configure Fieldbus Settings

Be aware

Fieldbus settings only take effect when **Settings>Fieldbus Settings>Apply fieldbus settings** is used (step 6). These settings also need to be saved to remain active after a power cycle.

1. Open the console by following the steps given in Section 3.2.1 or 3.2.3.
2. In the console, open the menu **Settings** by pressing **<1>**.

```
----- [ PSC-ANY-EXT CONSOLE ] -----
Choose one of the following sub-menus by pressing the corresponding key:
1: Settings
2: Info Panel
3: Manual Control
4: Save and Reset
5: Error History
```

- Open the menu **Fieldbus Settings** by pressing **<1>** again.

```
-----[ SETTINGS ]-----
<ESC> to return to the main menu or <B> to return to the previous menu.

Choose one of the following submenus:
1: Fieldbus Settings
2: Power Supply Settings
3: Console Settings
4: Calibration Settings
```

- Decide whether the fieldbus is Ethernet-based or serial-based.
- Set the fieldbus settings depending on communication type of the Anybus insert on the fieldbus side.

- Press **<1>** and type the password (default: **"depower<ENTER>"**) to **Save Settings**. The password is case insensitive

```
-----[ SAVE AND RESET ]-----
<ESC> to return to the main menu or <B> to return to the previous menu.

Choose an option:
1: Save Settings
2: Undo changes
3: Load default Settings
4: Factory Reset
```

```
-----[ SAVE PROFILE ]-----
<ESC> to return to the main menu or <B> to return to the previous menu.

Confirm you wish to overwrite the current settings Yes/n.
Enter Password: depower
```

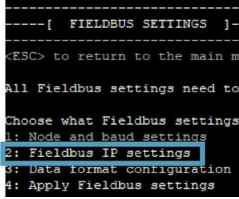
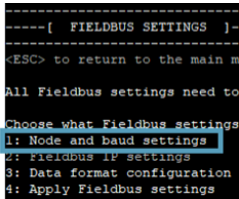
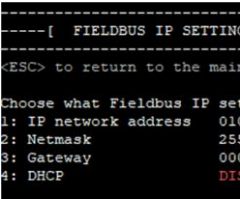
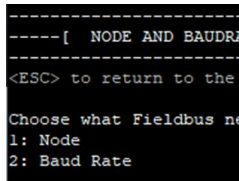
Ethernet-based	Serial-based
<p>5.1 Press <2> to enter Fieldbus IP settings.</p> 	<p>5.1 Press <1> to enter Node and baud settings.</p> 
<p>5.2 Set-up the Anybus address.</p> 	<p>5.2 Set-up the Anybus node address and baud rate.</p> 

- Press **** to go back to Fieldbus Settings.
- Apply fieldbus settings by pressing **<4>** and typing **"Yes<ENTER>"**.

```
-----[ FIELDBUS SETTINGS ]-----
<ESC> to return to the main menu or <B> to return to the previous menu.

All Fieldbus settings need to be applied before the changes take effect.

Choose what Fieldbus settings you want to change:
1: Node and baud settings
2: Fieldbus IP settings
3: Data format configuration
4: Apply Fieldbus settings

-----[ APPLY ]-----
Are you sure you want to apply the Fieldbus settings? Yes/n
The PSC-ANY-EXT will temporarily be disconnected from the network.
Yes
```

- Press **<ESC>** to return to the main menu.
- Press **<4>** to enter the **Save and Reset** menu.

```
-----[ PSC-ANY-EXT CONSOLE ]-----

Choose one of the following sub-menus by pressing the corresponding key:
1: Settings
2: Info Panel
3: Manual Control
4: Save and Reset
5: Error History
```

3.3.2 Data Format Configuration

The power supply voltage and current settings can be configured to use either float format or 16-bit format. 16-bit format makes use of 16-bit values for voltage and current with 62500 being the maximum value (e.g. a voltage of $\frac{1}{2}V_{max} = 31250$ bits). Programming to 65535 is permitted.

By default, Float Format A is used. Float format uses more data and is therefore slower but easier to work with. 16-bit format is recommended if the PSC-ANY-EXT is placed in a highspeed or real-time environment since it uses less data and is therefore significantly faster.

The following steps can be executed to use the PSC-ANY-EXT in 16-bit format. If float format is the preferred format, these steps can be skipped. More on data formats in the "Fieldbus Implementation Guide" which can be found on www.DeltaPowerSupplies.com by navigating to "Products > Interfaces > Anybus unit (external) > Manuals".

- Open the console by following the steps given in Section 3.2.1 or 3.2.3.
- In the console, open the menu **Settings** by pressing **<1>**.

```
-----[ PSC-ANY-EXT CONSOLE ]-----

Choose one of the following sub-menus by pressing the corresponding key:
1: Settings
2: Info Panel
3: Manual Control
4: Save and Reset
5: Error History
```

- Open the menu **Fieldbus Settings** by pressing **<1>** again.

```
-----[ SETTINGS ]-----
<ESC> to return to the main menu or <B> to return to the previous menu.

Choose one of the following submenus:
1: Fieldbus Settings
2: Power Supply Settings
3: Console Settings
4: Calibration Settings
```

- Open the menu **Data Format Configuration** by pressing **<3>**.

```
-----[ FIELDBUS SETTINGS ]-----
<ESC> to return to the main menu or <B> to return to the previous menu.

All Fieldbus settings need to be applied before the changes take effect.

Choose what Fieldbus settings you want to change:
1: Node and baud settings
2: Fieldbus IP settings
3: Data format configuration
4: Apply Fieldbus Settings
```

5. Press **<2>** to select **16-Bit Format**.
6. Return to **Fieldbus Settings** by pressing ****. Press **<4>** to **Apply Fieldbus Settings**.

```
-----[ DATA FORMAT CONFIGURATION ]-----
<ESC> to return to the main menu or <B> to return to the previous menu.
Choose the desired Data Format:
1: Float Format A
2: 16-Bit Format B
```

```
-----[ FIELDBUS SETTINGS ]-----
<ESC> to return to the main menu or <B> to return to the previous menu.
All Fieldbus settings need to be applied before the changes take effect.
Choose what Fieldbus settings you want to change:
1: Node and baud settings
2: Fieldbus IP settings
3: Data format configuration
4: Apply Fieldbus settings
```

7. Type **Yes<ENTER>** to confirm.

```
-----[ FIELDBUS SETTINGS ]-----
<ESC> to return to the main menu or <B> to return to the previous menu.
All Fieldbus settings need to be applied before the changes take effect.
Choose what Fieldbus settings you want to change:
1: Node and baud settings
2: Fieldbus IP settings
3: Data format configuration
4: Apply Fieldbus settings
-----[ APPLY ]-----
Are you sure you want to apply the Fieldbus settings? Yes/n
The PSC-ANY-EXT will temporarily be disconnected from the network.
Confirm: Yes
```

8. Press **<ESC>** to return to the main menu.

9. Press **<4>** to enter **Save and Reset**,

```
-----[ PSC-ANY-EXT CONSOLE ]-----
Choose one of the following sub-menus by pressing the corresponding key:
1: Settings
2: Info Panel
3: Manual Control
4: Save and Reset
5: Error History
```

10. Press **<1>** and type the password (default: **"depower<ENTER>"**) to **Save Settings**. The password is case insensitive.

```
-----[ SAVE AND RESET ]-----
<ESC> to return to the main menu or <B> to return to the previous menu.
Choose an option:
1: Save Settings
2: Undo changes
3: Load default Settings
4: Factory Reset
```

```
-----[ SAVE PROFILE ]-----
<ESC> to return to the main menu or <B> to return to the previous menu.
Confirm you wish to overwrite the current settings Yes/n.
Enter Password: depower
```

11. The PSC-ANY-EXT is now ready to communicate with the power supply using 16-bit format. Refer to Chapter 4 for instructions on how to communicate with the power supply using the PSC-ANY-EXT.

4 Power Supply Programming

Programming and monitoring of the power supply can be done using the Anybus insert, console or SCPI commands. Make sure to finish the setup and configuration (Chapter 3) before continuing with setting up the desired communication method.

When using an Anybus insert for programming and monitoring, the fieldbus side of the insert can be either ethernet or serial based. Consult Sections 4.1 and 4.2 for additional instructions on how to validate the setup. When using the USB interface of the PSC-ANY to program and monitor, consult sections 4.3 and 4.4 for instructions how to program the power supply using the console or through the SCPI commands.

4.1 Ethernet-based Fieldbus

Before using the actual protocol, let's validate the ethernet communication with the PSC-ANY-EXT. Keep in mind that this test does not work for EtherCAT. Use the "EtherCAT Detection" tool instead. This tool can be found on www.DeltaPowerSupplies.com by navigating to "Products > Interfaces > Anybus unit (external) > Tools".

To validate the connection communication setup following the instruction below:

1. Ensure that the PSC-ANY-EXT is set up as shown in Figure 2.3.
2. Find the IP-address of the Anybus insert either by looking in the 'Info Panel' of the PSC-ANY or Download [HMS Ipconfig](#), an Anybus insert scanner.
3. The IP-address of the Anybus insert will show up.

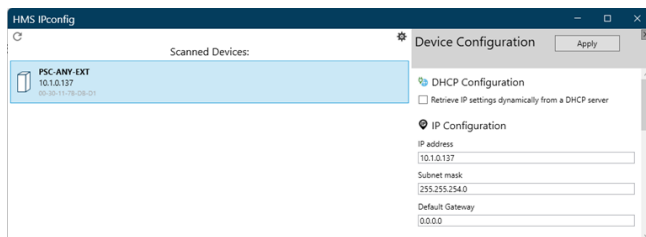

4. The IP address can be entered into a web browser, such as Firefox or Chrome, to access the Anybus Control Panel. If the control panel is accessible, correct communication setup of the PSC-ANY-EXT has been validated. See Figure 4.1 for an illustration of the Anybus insert's web interface.

It is possible to program and monitor the power supply using this web interface. However, changes using this panel will get reset after a power cycle. Even after using **Main Menu>Save and Reset>Save Settings** in the console. Use this panel for testing and temporary manual control only. Usage of SMTP and MQTT are not supported, nor disabled by Delta Elektronika. Refer to the "Fieldbus Implementation Guide" on www.DeltaPowerSupplies.com for the definitions of STS, Status Register A and Status Register B.

Correct communication setup of the PSC-ANY-EXT has been validated. Continue with Chapter 5 to implement the PSC-ANY-EXT fieldbus into your environment.

4.2 Serial-based Fieldbus

Before using the communication protocol, let's validate that the serial-based insert is detected using the console.

1. Ensure that the PSC-ANY-EXT is set up as shown in Figure 2.3.
2. Open the console by following the steps given in Section 3.2.1 or 3.2.3.
3. In the console, open the menu **Info Panel** by pressing **<2>**.

```

-----[ INFO PANEL ]-----[ FW-Version: V01.00 Date: 02-06-25]
-----[ 000010434901 ]--[ HW-Version 1 ]--
FUD: NO FUD DATA

Module Detected:           Yes
Anybus Module:            CANopen      FW-Version: 1.2.1
Node-ID:                  000
Baudrate:                 10kbps
Power Supply Detected:    Yes
Power Supply Model:      15V-10A
CVlim:                   15.60V
CClim:                   10.40A

CVprog:                   0.000V
CCprog:                   0.000A

CVmon:                    -0.002V
CCmon:                    -0.006A
  
```

4. Ensure that the correct Anybus insert is detected.

Correct setup of the PSC-ANY-EXT has now been validated. Continue with Chapter 5 to implement the PSC-ANY-EXT fieldbus into your environment.



Figure 4.1: Anybus insert's web interface

4.3 Serial Control: Console Mode

Be aware

Switching the control mux from 'CONSOLE' to 'FIELDBUS' and vice versa always enables Remote Shutdown (RSD).

Follow these steps to take control over the power supply using the console or the web interface.

1. Ensure that the PSC-ANY-EXT is set up as shown in Figure 2.3.
2. Open the console by following the steps given in Section 3.2.1 or 3.2.3.
3. In the console, open the menu **Manual Control** by pressing **<3>**.

```
-----[ PSC-ANY-EXT CONSOLE ]-----
Choose one of the following sub-menus by pressing the corresponding key:
1: Settings
2: Info Panel
3: Manual Control
4: Save and Reset
5: Error History
```

The console will show 4 options:

- 1: **Switch Control MUX setting:** Switch control between 'CONSOLE' or 'FIELDBUS'.
- 2: **CVprg:** the manual output voltage setting. Keep in mind that this only becomes active when the control MUX is set to "CONSOLE".
- 3: **CCprg:** the manual output current setting. Keep in mind that this only becomes active when The control MUX is set to "CONSOLE".
- 4: **RSD:** Makes the remote shutdown 'ACTIVE' or 'DISABLED'.

```
Choose the number and enter the desired value followed by <ENTER> to confirm.
1: Switch Control MUX setting:      FIELDBUS
-----
2: CVprg:                          0.000 V
3: CCprg:                          0.000 A
4: RSD:                             DISABLED
```

4. Press **<1>** to switch from 'FIELDBUS' to 'CONSOLE' control.

If an ethernet-based fieldbus is being used, it is now possible to adjust programming and status values using the web interface as well. Chapter 4.1 explains how to open the web-interface of the unit.

5. Press **<2>**, enter the desired output voltage and confirm by pressing **<ENTER>**.
6. Press **<3>**, enter the desired output current and confirm by pressing **<ENTER>**.
7. Press **<4>**, to toggle the RSD status. (RSD enabled means that the power supply output is off).
8. Press **<ESC>** to return to the main menu.

```
-----[ PSC-ANY-EXT CONSOLE ]-----
Choose one of the following sub-menus by pressing the corresponding key:
1: Settings
2: Info Panel
3: Manual Control
4: Save and Reset
5: Error History
```

9. If it is preferred to save these settings, Press **<4>** to enter **Save and Reset**.

10. Press **<1>** and type the password (default: "depower<ENTER>") to **Save Settings**

```
-----[ SAVE AND RESET ]-----
<ESC> to return to the main menu or <B> to return to the previous menu.
Choose an option:
1: Save Settings
2: Undo changes
3: Load default Settings
4: Factory Reset
```

```
-----[ SAVE PROFILE ]-----
<ESC> to return to the main menu or <B> to return to the previous menu.
Confirm you wish to overwrite the current settings Yes/n.
Enter Password: depower
```

4.4 Serial Control: SCPI Mode

1. Make sure the PSC-ANY-EXT is in SCPI-Terminal mode. See Section 3.2 if it isn't or if you're unsure.
2. Use the following command to set the CTRL MUX so that SCPI-commands control the power supply.

```
SYST:COM:CTR 1
```

3. Chapter 10 lists all the SCPI commands specifically for the PSC-ANY-EXT. They are also summed up in chapter 0. For example, these commands can be used to set CVprg and CCprg.
4. Don't forget to save the PSC-ANY-EXT configuration changes by sending **SYSTem:INterface:ANYbus:SETtings:APPLY** to save fieldbus settings and ***SAV<sp><password>** (default password: depower) to save all settings in memory.
5. Switching back to the console can be achieved by sending **SYSTem:COMmunicate:CONsole**.
6. Press **<1>** and type the password (default: "depower<ENTER>") to Save Settings.

5 Fieldbus Implementation

Fieldbuses can be implemented using the "Fieldbus Implementation Guide" which can be found at www.DeltaPowerSupplies.com by navigating to "Products > Interfaces > Anybus unit (external) > Manuals > Fieldbus Implementation Guide". Examples can be found at "... > Anybus unit (external) > Examples". Keep in mind that data format B is not compatible with the PSC-ANY-EXT.

6 Resetting

6.1 Using console

Resetting the PSC-ANY-EXT to factory default settings using the console will reset the fieldbus-settings, calibration settings and inserted Anybus insert to factory default. Resetting only the calibration or fieldbus settings is also an option. The factory settings can be viewed in the table below. Resetting the PSC-ANY-EXT can be achieved as follows:

1. Ensure that the PSC-ANY-EXT is set up as shown in Figure 2.3.
2. Open the console by following the steps given in Section 3.2.1 or 3.2.3.
3. In the opened console, press <4> to open the menu **Save and Reset**.

```

-----[ INFO PANEL ]----- [ FW-Version: V01.00 Date: 02-06-20]
PUD: NO PUD DATA [ 000010434901 ]-- [ HW-Version 1 ]--
Module Detected:      Yes
Anybus Module:       CANopen      FW-Version: 1.2.1
Node-ID:             000
Baudrate:           10Kbps
Power Supply Detected: Yes
Power Supply Model:  15V-10A
CVlim:              15.50V
CClim:              10.40A
CVprog:             0.000V
CCprog:             0.000A
CVmon:              -0.002V
CCmon:              0.000A
    
```

The console will show 4 options:

```

-----[ PSC-ANY-EXT CONSOLE ]-----
Choose one of the following sub-menus by pressing the corresponding key:
1: Settings
2: Info Panel
3: Manual Control
4: Save and Reset
5: Error History
    
```

- 1: **Save Settings:** Save the current settings of the PSC-ANY-EXT so that changes persist after a power cycle.
- 2: **Undo Changes:** Revert changes that have not yet been saved.
- 3: **Load Default Settings:** Loads the default fieldbus or calibration settings to factory settings depending on the submenu choice.
- 4: **Factory Reset:** Resets the fieldbus, calibration and Anybus insert to factory settings.

4. Choose the desired reset option by pressing <3> or <4> and typing **Yes<ENTER>**.

6.2 Using PSC-ANY-EXT Updater tool

Resetting the PSC-ANY-EXT to factory default settings using the console will reset the fieldbus-settings, calibration settings and inserted Anybus insert to factory default. Besides, it will reset the baud rate of the console to 9600 Baud and reset the unit to console mode. Resetting the PSC-ANY-EXT can be achieved as follows:

1. Ensure that the PSC-ANY-EXT is set up as shown in Figure 2.3.
2. Go to www.DeltaPowerSupplies.com and navigate to "Products > Interfaces > Anybus unit (external) > Software"
3. Download the "PSC-ANY-EXT Updater".
4. Open the "PSC-ANY-EXT Updater".
5. Select the correct COM-port.
6. Press "Factory reset device" to factory reset.

6.3 Factory Default Settings

Password	depower
----------	---------

PUD	No PUD data
-----	-------------

Calibration:	
Calibration (Gain):	1.000000
Calibration (Offset):	0
(CV-Prog & CC-Prog & CV-Mon & CC-Mon)	

Power Supply Model:	
Voltage Range:	5 V
Current Range:	5 A

Programming:	
RSD:	0 (Power Supply On)
CVprg:	0 V
CCprg:	0 A
CVlim:	5.5 V
CClim:	5.5 A

PROFINET:	
IP address:	192.168.000.000
Netmask:	255.255.255.000
Gateway:	000.000.000.000
DHCP:	Enabled

ModbusTCP:	
IP address:	192.168.000.000
Netmask:	255.255.255.000
Gateway:	000.000.000.000
DHCP:	Enabled

EtherCAT:	
IP address:	192.168.000.000
Netmask:	255.255.255.000
Gateway:	000.000.000.000

EtherNet/IP:	
IP address:	192.168.000.000
Netmask:	255.255.255.000
Gateway:	000.000.000.000
DHCP:	Enabled

PROFIBUS:	
Node address:	001
Data rate:	AUTO

CANopen:	
Node address:	001
Data rate:	AUTO

7 Calibration

Calibration of the standalone PSC-ANY-EXT has been executed from factory. Since Delta Elektronika power supplies are calibrated as well, it is not required to perform a combined calibration. However, accuracy can be improved slightly by doing so. When calibrating, be sure to use measuring equipment that is capable of measuring with higher precision than the step size of the used power supply. (Section 2.8)

WARNING
 Make sure that the conductor between the output terminals during CC-calibration is thick enough to handle the maximum current the power supply can provide. The power supply will be set to 100% current during calibration. Make sure that each step is read and executed carefully. See Figure 7.1 and Figure 7.2 for the individual calibration setups.

7.1 Calibrating Voltage

This step-by-step guide goes through calibrating the programming and monitoring of voltage for the combined PSC-ANY-EXT and power supply setup. It will do so by setting a voltage of about 2% and 100% of V_{max} respectively.

WARNING
 The console will automatically apply a voltage on the output of the power supply when entering **Calibrate Voltage**.

Be aware
 For safety reasons, 'RSD' is set to ACTIVE and 'CTRL MUX' is set to CONSOLE after calibrating. These settings can be adjusted in **<3> Manual Control**. More details can be found in Section 4.3.

1. Make sure that the power supply is turned off.
2. Set up the CV-Calibration configuration as seen in Figure 7.1.
3. Turn the power supply on.
4. Open the console by following the steps given in Section 3.2.1 or 3.2.3.

5. Press **<1>** to select **Settings**.

```
----- [ PSC-ANY-EXT CONSOLE ] -----
Choose one of the following sub-menus by pressing the corresponding key:
1: Settings
2: Info Panel
3: Manual Control
4: Save and Reset
5: Error History
```

6. Press **<1>** to **Calibrate Voltage**.

```
----- [ CALIBRATION SETTINGS ] -----
<ESC> to return to the main menu or <B> to return to the previous menu.

Calibration Options:
1: Calibrate Voltage
2: Calibrate Current
3: Adjust calibration
```

7. Enter the measured voltage (2% of V_{max}) in the console with as much precision as possible and hit **<ENTER>**.

```
----- [ VOLTAGE CALIBRATION ] -----
<ESC> to return to the main menu or <B> to return to the previous menu.

!!!WARNING!!!
Please refer to the manual for setup instructions.
Calibration sequence uses full output range. Please make sure the Voltage and Current range have been set correctly before starting.

Enter the measured output voltage of the Power Supply and press <ENTER> to confirm.
0.40392
```

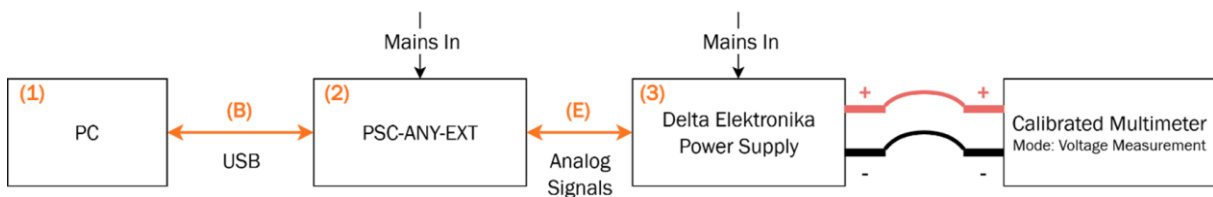

Figure 7.1: CV-Calibration setup

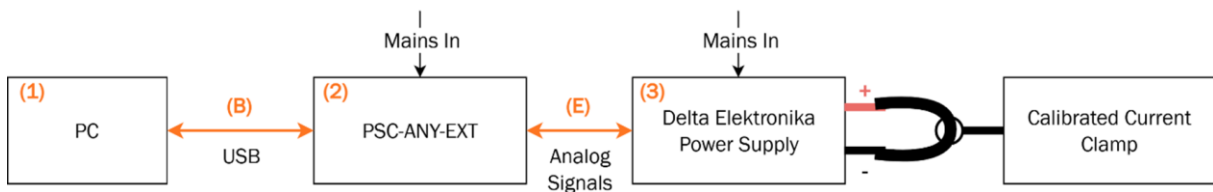

Figure 7.2: CC-Calibration setup

- Again, enter the measured voltage (V_{\max}) in the console and hit **<ENTER>**.

```
Enter the measured output voltage of the Power Supply and press <ENTER>
to confirm.
14.8780
Calibration successful.
```

- Press **<ESC>** to return to the main menu.
- Press **<4>** to enter **Save and Reset**,

```
-----[ PSC-ANY-EXT CONSOLE ]-----
Choose one of the following sub-menus by pressing the corresponding key:
1: Settings
2: Info Panel
3: Manual Control
4: Save and Reset
5: Error History
```

- Press **<1>** and type the password (default: **"depower<ENTER>"**) to **Save Settings**.

7.2 Calibrating Current

This step-by-step guide goes through calibrating the programming and monitoring of current for the combined PSC-ANY-EXT and power supply setup. It will do so by setting a current of about 2% and 100% of V_{\max} respectively.

WARNING

The console will automatically apply a current on the output of the power supply when entering **Calibrate Current**.

WARNING

Make sure the conductor between the output terminals is thick enough to handle the maximum current the power supply can provide. The power supply will be set to 100% current during calibration!

Be aware

For safety reasons, 'RSD' is set to ACTIVE and 'CTRL MUX' is set to CONSOLE after calibrating. These settings can be adjusted in <3>Manual Control. More details can be found in chapter 4.3

- Make sure that the power supply is turned off.
- Set up the current calibration configuration as seen in Figure 7.2.
- Turn the power supply on.
- Open the console by following the steps given in Section 3.2.1 or 3.2.3.
- Press **<1>** to select **Settings**.

```
-----[ PSC-ANY-EXT CONSOLE ]-----
Choose one of the following sub-menus by pressing the corresponding key:
1: Settings
2: INFO Panel
3: Manual Control
4: Save and Reset
5: Error History
```

- Press **<4>** to select **Calibration Settings**.

```
-----[ SETTINGS ]-----
<ESC> to return to the main menu or <B> to return to the previous menu.
Choose one of the following submenus:
1: Fieldbus Settings
2: Power Supply Settings
3: Console Settings
4: Calibration Settings
```

- Press **<2>** to **Calibrate Current**.

```
-----[ CALIBRATION SETTINGS ]-----
<ESC> to return to the main menu or <B> to return to the previous menu.
Calibration Options:
1: Calibrate Voltage
2: Calibrate Current
3: Adjust calibration
4: Advanced calibration settings
```

- Enter the measured current in the console with as much precision as possible and hit **<ENTER>**.
- Again, enter the measured current in the console and hit **<ENTER>**.

```
-----[ CURRENT CALIBRATION ]-----
!!!WARNING!!!
The PS needs to be short circuited for this mode, please refer to the manual.
Enter the measured output current of the Power Supply and press <ENTER>
to confirm.
0.2512
Enter the measured output current of the Power Supply and press <ENTER>
to confirm.
6.5723
Calibration successful.
```

- Press **<ESC>** to return to the main menu.
- Press **<4>** to enter **Save and Reset**.

```
-----[ PSC-ANY-EXT CONSOLE ]-----
Choose one of the following sub-menus by pressing the corresponding key:
1: Settings
2: Info Panel
3: Manual Control
4: Save and Reset
5: Error History
```

- Press **<1>** and type the password (default: **"depower<ENTER>"**) to **Save Settings**.

```
-----[ SAVE AND RESET ]-----
<ESC> to return to the main menu or <B> to return to the previous menu.
Choose an option:
1: Save Settings
2: Undo changes
3: Load default Settings
4: Factory Reset
```

```
-----[ SAVE PROFILE ]-----
<ESC> to return to the main menu or <B> to return to the previous menu.
Confirm you wish to overwrite the current settings Yes/n.
Enter Password: depower
```

7.3 Calibration Adjust

It is recommended to auto-calibrate using the leading paragraphs. However, it is possible to make manual adjustments to the calibration parameters. This can be done by adding a gain factor and offset to the calibration parameters.

WARNING

Adjustments to the calibration are performed immediately.

1. Open the console by following the steps given in Section 3.2.1 or 3.2.3.
2. Press **<1>** to select **Settings**.

```
-----[ PSC-ANY-EXT CONSOLE ]-----
Choose one of the following sub-menus by pressing the corresponding key:
1: Settings
2: Info Panel
3: Manual Control
4: Save and Reset
5: Error History
```

3. Press **<4>** to select **Calibration Settings**.

```
-----[ SETTINGS ]-----
<ESC> to return to the main menu or <B> to return to the previous menu.

Choose one of the following submenus:
1: Fieldbus Settings
2: Power Supply Settings
3: Console Settings
4: Calibration Settings
```

4. Press **<3>** to **Adjust calibration**.

```
-----[ CALIBRATION SETTINGS ]-----
<ESC> to return to the main menu or <B> to return to the previous menu.

Calibration Options:
1: Calibrate Voltage
2: Calibrate Current
3: Adjust calibration
4: Advanced calibration settings
```

5. Press the **<Number>** in front of the gain or offset parameter that needs adjusting and enter a new value.

```
-----[ CALIBRATION ADJUSTMENT SETTINGS ]-----
<ESC> to return to the main menu or <B> to return to the previous menu.

Please refer to the manual for setup instructions.
Adjust the gain and offset by hand.
Gain max +/-10%, Offset is max +/- 13% of In/Output range.

Choose the number and enter the desired factor followed by <ENTER> to confirm.

1: CV-Prog Gain factor 1.000000 x
2: CV-Prog Offset 0.000000 V
3: CC-Prog Gain factor 1.000000 x
4: CC-Prog Offset 0.000000 A
5: CV-Mon Gain factor 1.000000 x
6: CV-Mon Offset 0.000000 V
7: CC-Mon Gain factor 1.000000 x
8: CC-Mon Offset 0.000000 A

New Value: 1.000001
```

6. Press **<ESC>** to return to the main menu
7. Press **<4>** to enter **Save and Reset**,

```
-----[ PSC-ANY-EXT CONSOLE ]-----
Choose one of the following sub-menus by pressing the corresponding key:
1: Settings
2: Info Panel
3: Manual Control
4: Save and Reset
5: Error History
```

8. Press **<1>** and type the password (default: **"depower<ENTER>"**) to **Save Settings**.

```
-----[ SAVE AND RESET ]-----
<ESC> to return to the main menu or <B> to return to the previous menu.

Choose an option:
1: Save Settings
2: Undo changes
3: Load default Settings
4: Factory Reset
```

```
-----[ SAVE PROFILE ]-----
<ESC> to return to the main menu or <B> to return to the previous menu.

Confirm you wish to overwrite the current settings Yes/n.
Enter Password: depower
```

8 Firmware Updating

It is highly recommended to regularly check for updates to make sure the PSC-ANY-EXT benefits of the latest improvements. Settings saved to the PSC-ANY-EXT will not get reset to factory default by updating. To update the firmware, follow these steps:

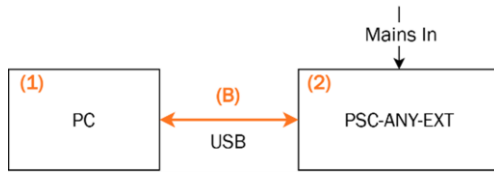

Figure 8.1. Firmware updating configuration

1. Go to www.DeltaPowerSupplies.com and navigate to “Products > Interfaces > Anybus unit (external) > Firmware”
2. Download the “Firmware updater Anybus interface unit” from the website. The updater, along with release note will be inside of the zip-file.
3. Download the latest firmware as well. The .bin firmware file, along with release note will be inside of the zip-file.
4. Set up the PSC-ANY-EXT as seen in Figure 8.1.
5. Open the PSC-ANY-EXT Updater.
6. Select the correct COM-port.
7. Press “Select firmware file” to browse and select the downloaded firmware file.
8. Press “Start programming” to start updating the firmware. This will take about a minute.
9. If the final message should show “Firmware updated successfully”.

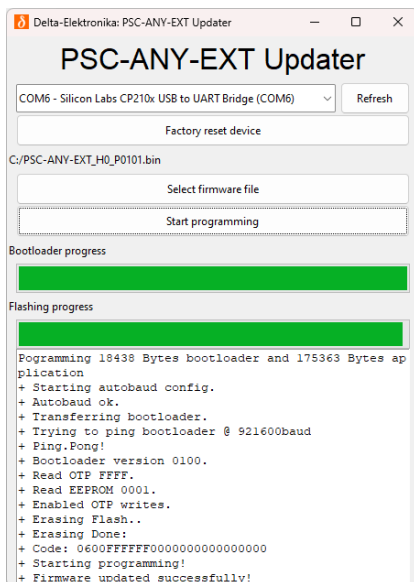

Figure 8.2. PSC-ANY-EXT Updater

9 Troubleshooting

Always verify that the LED statuses match the expected system statuses first. The LED definitions can be found in Chapter 2. This will help get the PSC-ANY-EXT up and running quickly. If the statuses don't match, refer to the first paragraph. Otherwise, skip it.

9.1 LED Statuses

Make sure the LED statuses are correct according to the current state of the PSC-ANY-EXT. The states can be seen in Table 2.1.

9.1.1 Problem 1.1: MOD is blinking red.

Make sure that the fieldbus is set-up correctly and that the configured IP-address is not in use on the same network yet.

9.1.2 Problem 1.2: ACT is green, but it should be red.

The power supply is controlled by the fieldbus and not manually controlled. In the console, go to **<3> Manual Control** and make sure that **<1> Switch Control MUX Setting** is set to 'CONSOLE'. Make sure to save this setting by going back to the **Main Menu**, opening **<4> Save and Reset** and pressing **<1> Save Settings** (default password: depower).

```

-----[ MANUAL CONTROL ]-----
-----
<ESC> to return to the main menu or <B> to return
to the previous menu
!WARNING!:
These settings control the output directly!
Please confirm all settings are correct before using
RSD will be enabled automatically when setting CTRL
mode to manual control
Choose the number and enter the desired value followed
by <B>
1: Switch Control MUX setting:          CONSOLE
-----
2: CVprog:                             0.000 V
3: CCprog:                              0.000 A
4: RSD:                                 ACTIVE
-----

```

9.1.3 Problem 1.3: ACT is red, but it should be green.

The power supply is manually controlled and not controlled by the fieldbus. In the console, go to **<3> Manual Control** and make sure that **<1> Switch Control MUX Setting** is set to 'FIELDBUS'. Make sure to save this setting by going back to the **Main Menu**, opening **<4> Save and Reset** and pressing **<1> Save Settings** (default password: depower).

9.1.4 Problem 1.4: USB is off while USB cable is connected.

- Ensure that the USB cable is fully plugged into both the PC and PSC-ANY-EXT.
- Make sure the USB cable that came with the PSC-ANY-EXT is being used since this cable is capable of transferring data. Some cables on the market are only capable of transferring power and are missing data line.

9.2 Console

- 9.2.1 Problem 2.1: COM-port is not showing up in "Device Manager".
- Make sure the latest drivers are installed. More information on this in chapter 3.2.1.
 - Try plugging the USB-connector into a different port on the PC.
 - Make sure the USB cable that came with the PSC-ANY-EXT is being used since this cable is capable of transferring data. Some cables on the market are only capable of transferring power and are missing data lines.
- 9.2.2 Problem 2.2: The console does not open
- Make sure to press ESC in the terminal program. This should open the console.
 - Make sure the PSC-ANY-EXT is being powered. The green LED labelled "PWR" should be lit.
 - Close the terminal, turn off the PSC-ANY-EXT and wait for 5 seconds. Turn the PSC-ANY-EXT back on, open the terminal and reopen the console by pressing **<ESC>**.
 - Make sure the right COM-port is being used. More information on this in chapter 3.2.1.
 - Make sure the correct baud rate is being used. On default this is 9600 Baud, however it may have been changed to 19200, 38400, 57600, 115200, 230400, 460800, 921600. Try opening the console using these baud rates.
 - The PSC-ANY-EXT may be in SCPI mode. Follow the steps in chapter 3.2.3. to open the SCPI terminal. Try sending ***IDN?** using all possible baud rates. If it responds, send the command **SYSTem:CONsole:SWItch** to switch back to console mode.
- 9.2.3 Problem 2.3: The info panel shows "Fieldbus Detected: Undefined".
- Is the Anybus insert used supported by Delta Elektronika? Visit "www.DeltaPowerSupplies.com Products > Interfaces > Anybus unit (external)" to see the supported inserts.
 - Turn off the PSC-ANY-EXT. Remove the Anybus insert from the PSC-ANY-EXT, then reinsert it securely. Tighten both screws on the insert, as described in chapter 3.1.1. Turn the PSC-ANY-EXT back on, then reopen the console and check if the insert is detected.
- 9.2.4 Problem 2.4: Stuck in SCPI terminal.
- Follow the steps in chapter 3.2.2 to open the SCPI terminal. Using the terminal, send the command **SYSTem:CONsole:SWItch**. The normal console can now be used again.

9.3 Programming and Monitoring

- 9.3.1 Problem 3.1: Unable to program or monitor the power supply using a fieldbus.
- Open the console and press **<2>** to open the **Info Panel**. Make sure that the insert is detected. If not, refer to problem 2.3: "*The info panel shows "Fieldbus Detected: Undefined"*".
 - Follow the steps in chapter 4.3 to program the power supply using the console. This will help determine whether the issue is with the communication between the PSC-ANY-EXT and the power supply, or if it's related to the fieldbus. If you're unable to program the power supply via the console, it is not a fieldbus related problem. Refer to Problem 3.2: "*Unable to program or monitor the power supply using the console.*"

- When using an ethernet-based fieldbus, follow the steps in chapter 4.1 to program the power supply using the web interface. If this works, there is something wrong with the implementation of the fieldbus, but the setup is working correctly. Refer to chapter 5.
 - RSD (Remote Shutdown) may be active. When RSD is activated, it ensures that **(3)** does not supply power. Therefore, RSD must be inactive for the power supply to provide power. However, even when RSD is active, you can still program CVprg and CCprg. Their settings just aren't active on the output terminals. When RSD is active, check if the power supply CVprg and CCprg settings are correctly programmed on the power supply display.
 - Cable **(A)** may be faulty. Make sure it is connected tightly. If this doesn't work, try replacing the cable.
- 9.3.2 Problem 3.2: Unable to program or monitor the power supply using the console.
- When using a power supply that features M/P (Manual/Program) switches on the back, make sure that the switches are set to 'P'.
 - Make sure that the DB15 cable is properly connected and fixated on both the PSC-ANY-EXT and power supply.

If problems persist, contact support through one of the web-forms.

10 SCPI Implementation

10.1 SCPI Conventions

The PSC-ANY-EXT has a command set, which includes commands compatible with the SCPI language (Standard Commands for Programmable Instruments). This Chapter lists all available SCPI commands to be used over the USB interface of the PSC-ANY.

10.2 Syntax

The command descriptions contain the syntax of the instructions and show the form in which these commands can be sent to the PSC-ANY-EXT. It is allowed either to use the short form or the entire command. For example:

SOURce:VOLtage<sp>5<term> can be send as:

sour:vol<sp>5<term>

source:volt<sp>5<term>

source:voltage<sp>5<term>

sour:voltage<sp>5<term>

SoURce:VoLt<sp>5<term>

(Sending mixed upper- and lowercase is allowed)

10.3 Query

Commands ending with a question mark "?" (ASCII character 3FH, 63d) are interpreted as a query. If it is a valid command, the unit will respond with an answer. Otherwise an error is generated.

10.4 Space <sp>

Within the syntax spaces are used, indicated by <sp>, which is equal to ASCII character 20H (32d).

10.5 Terminator <term>

At the end of each command or query, a terminator character is required, indicated by <term>. Each reply on a valid query will end with <term>. Default terminator is a linefeed (ASCII character OAH, 10d).

10.6 Parameters

Within this document, parameters are used to indicate the form of data sent to or coming from the PSC-ANY-EXT.

<NR1> = positive integers: 0,1,2,3,...

<NR2> = floating point : 3.22, 0.06, etc.

<boolean> = False or True parameter : 0 or 1, OFF or ON.

[] = It is allowed to use or to skip this part of the command.

<IP> = x[xx].x[xx].x[xx].x[xx] with x=0..9.

10.7 General Instructions

10.7.1 *IDN?

This command is used to read the identification string of the PSC-ANY-EXT. The string contains the name, the version of the firmware and the serial number of the Power Supply.

Syntax: ***IDN?<term>**

The response string has 5 fields, separated by commas.

For example :

DELTA<sp>ELEKTRONIKA<sp>BV,PSC<sp>ANY<sp>EXT<sp>0095,000010361215,0<term>

The first field shows the manufacturer's name.

The second field shows the interface name + firmware version.

The third field shows the serial number of the PSC-ANY-EXT.

The last field is reserved for future implementations.

10.7.2 *PUD

PUD is an abbreviation for Protected User Data. This command allows the user to give the power supply his own name for identification or to store relevant data.

For example names like "Motor Controller Setup 3", "Battery Simulator" or "Calibrated July 28th 2025". This information can be maximum 72 characters long and is stored into non-volatile memory (see command *SAV).

Syntax: ***PUD<sp><data><term>** data = A-Z, a-z, 0-9, <sp>, _ and -, 72 maximum

To read the Protected User Data:

Syntax: ***PUD?<term>**

10.7.3 *SAV

To store all relevant settings, this command saves them into non-volatile memory.

WARNING

This command overrides the settings already stored in memory.

A summary of the saved setting are shown below:

Calibration gain current measure	: CALIbrate:CURrent:MEASure:GAIn
Calibration offset current measure	: CALIbrate:CURrent:MEASure:OFFset
Calibration gain voltage measure	: CALIbrate:VOLtage:MEASure:GAIn
Calibration offset voltage measure	: CALIbrate:VOLtage:MEASure:OFFset
Calibration gain current	: CALIbrate:CURrent:GAIn
Calibration offset current	: CALIbrate:CURrent:OFFset
Calibration gain voltage	: CALIbrate:VOLtage:GAIn
Calibration offset voltage	: CALIbrate:VOLtage:OFFset
Maximum Output Voltage	: SOURce:VOLtage:MAXimum
Maximum Output Current	: SOURce:CURrent:MAXimum
System RSD	: SYSTem:RSD
System limit voltage	: SYSTem:LIMits:VOLtage
System limit current	: SYSTem:LIMits:CURrent
System interface address	: SYSTem:INTerface:ANYbus:SETTING X,ADDRESS
System interface subnetmask	: SYSTem:INTerface:ANYbus:SETTING X,SUBNETMASK
System interface gateway	: SYSTem:INTerface:ANYbus:SETTING X,GATEWAY
System interface DHCP	: SYSTem:INTerface:ANYbus:SETTING X,DHCP
System interface node	: SYSTem:INTerface:ANYbus:SETTING X,NODE
System interface baud rate	: SYSTem:INTerface:ANYbus:SETTING X,BAUD
System interface data format	: SYSTem:INTerface:ANYbus:SETTING X,DATAFORMAT
Baud Rate	: SYSTem:COMmunicate:BAUD
Ctrlmux	: SYSTem:COMmunicate:CTRLmux
Password	: SYSTem:PASSword
Protected User Data	: *PUD
Terminal Mode (Console/SCPI)	: -

Syntax: ***SAV<term>**

When a password is used, the only way to store these relevant settings into memory is to use:

Syntax: ***SAV<sp><password><term>**

10.7.4 *RST

This reset command sets the power supply in a save defined state. The table below gives an overview of the settings made after sending this reset command or after power-on of the PSC-ANY-EXT:

Setting	Value	Set after *RST:	Set after power-on:
SOURce:VOLtage	0	YES	YES
SOURce:CURrent	0	YES	YES
SYSTem:RSD	1 (ON)	YES	YES
CTRL MUX	1 (SCPI-Mode)	YES	NO

Syntax: ***RST<term>**

10.7.5 *RCL

This command recalls calibration settings and the Protected User Data. This can be used in case of accidental override of these settings.

Syntax: ***RCL<term>**

10.7.6 *OPC?

OPC stands for Operation Complete. This command can be used to verify if previous commands have been completed.

Syntax: ***OPC<term>**

If successful, the answer is: 1<term>

10.8 Source Subsystem

10.8.1 Introduction

First, the PSC-ANY-EXT should know which type of power supply it will be controlling. Therefore, two commands are available to set the maximum output voltage and the maximum output current. Default settings are 5V / 5 A. These settings must be changed for correct operation.

Both parameters (output voltage and output current) have a working range from 0 to the maximum output voltage / current of the power supply. The response strings contain a floating-point value with 4 digits of precision.

10.8.2 Set Output Voltage

To set the output voltage of the power supply:

Syntax: **SOURce:VOLtage<sp><NR2><term>**

To read the last settings, send the query:

Syntax: **SOURce:VOLtage?<term>**

For example, the answer is: 14.000<term>

10.8.3 Set Output Current

To set the output current of the power supply:

Syntax : **SOURce:CURrent<sp><NR2><term>**

To read the last settings, send the query:

Syntax : **SOURce:CURrent?<term>**

For example, the answer is: 14.000<term>

10.8.4 Maximum Output Voltage

To set the maximum output voltage of the power supply:

Syntax : **SOURce:VOLtage:MAXimum< sp><NR2><term>**

To read the last settings, send the query:

Syntax : **SOURce:VOLtage:MAXimum?<term>**

For example, the answer is: 14.000<term>

Maximum Output Current

To set the maximum output current of the power supply:

Syntax : **SOURce:CURrent:MAXimum<sp><NR2><term>**

To read the last settings, send the query:

Syntax : **SOURce:CURrent:MAXimum?<term>**

For example, the answer is: 14.000<term>

10.8.5 Output Voltage stepsize

To read the programming step size of the output voltage, send the query:

Syntax : **SOURce:VOLtage:STEPSize?<term>**

The reply will be in scientific notation, with an accuracy of 15 decimals. e.g.: 8.935988545417786e-01<term>

This represents the smallest voltage programming step possible.

10.8.6 Output Current stepsize

To read the programming step size of the output current, send the query:

Syntax : **SOURce:CURrent:STEPSize?<term>**

The reply will be in scientific notation, with an accuracy of 15 decimals. e.g.: 8.935988545417786e-01<term>

This represents the smallest current programming step possible.

10.9 Measure Subsystem

10.9.1 Introduction

To measure the power supply output parameters Voltage and Current, two different queries are available for each parameter format.

These commands measure the actual output parameters, which are not necessarily the same as the output settings like SOURce:VOLTage, SOURre:CURrent,

If for example the output settings are 15 V and 5 A and the power supply is in CC-mode (Constant Current), the output voltage is not equal to the setting of 15 V, but less.

10.9.2 Measure Output Voltage

To measure the output voltage of the power supply:

Syntax : **MEASure:VOLTage?<term>**

The resolution of the answer is 16 bits. e.g. 10.001764<term>

10.9.3 Measure Output Current

To measure the output current of the power supply:

Syntax : **MEASure:CURrent?<term>**

The resolution of the answer is 16 bits. e.g. 10.001764<term>

10.10 Calibrate Subsystem

10.10.1 Introduction

The calibration of the PSC-ANY-EXT is done during production. However, periodical check and calibration is recommended. At power-on, the calibration settings are restored.

There are eight parameters to calibrate. Four related to the voltage measurement and four related to the current measurement. Keep in mind that calibration parameters are only used in float format.

Default settings for the offsets are 0, and default settings for the gains are 1. The resolution of both settings and readings are 6 digits.

WARNING

High currents may flow when calibrating the current parameters. High voltages may exist when calibrating the voltage parameters.

For proper calibration it is recommended to use this order (an SM60-100 is used as example) :

1. Set output voltage of the power supply to e.g. 1% of the maximum output voltage. SOUR:VOLT0.6
2. Calibrate the source voltage offset, so the output voltage is as close as possible to 0.6 V
3. Calibrate the measure voltage offset, so the result of the command MEASure:VOLTage? is as close as possible to 0.6 V.
4. Set the output voltage to maximum.
5. Calibrate the source voltage gain, so the output voltage is as close as possible to the maximum voltage, 60 V.
6. Calibrate the measure voltage gain, so the result of the command MEASure:VOLTage? is as close as possible to the actual output voltage, 60 V.

Same principle is used for the current calibration.

Default settings for the offsets are 0, and default settings for the gains are 1. The resolution of both settings and readings are 6 digits.

Note that both gain and offset changes influence the actual output parameter. After changing offset, check if the gain has to change. And vice versa. To get a very accurate result, redo the calibration a few times.

Definitions

ProgrammedValue : The setting applied via fieldbus, console or SCPI.

actualValue: : The real output voltage or current measured with high precision and calibrated equipment.

measuredValue : The response of *MEASURE:VOLTage?* or *MEASURE:CURrent?*.

Equations

For SOURCE offset calibration, use the equation:

$$new_{offset} = old_{offset} + (programmedValue - actualValue)$$

For SOURCE gain calibration, use the equation:

$$new_{gain} = old_{gain} * \left(\frac{programmedValue}{actualValue} \right)$$

For MEASURE offset calibration, use the equation:

$$new_{offset} = old_{offset} + (actualValue - measuredValue)$$

For MEASURE gain calibration, use the equation:

$$new_{gain} = old_{gain} * \left(\frac{actualValue}{measuredValue} \right)$$

To save the calibration settings to the non-volatile memory, refer to chapter 10.7.

10.10.2 Calibrate Gain Source Voltage

To calibrate the gain of the voltage programming:

Syntax : **CALibrate:VOLTage:GAIIn<sp><NR2><term>**

With <NR2> = [0.900000 .. 1.100000]

To read the calibration setting:

Syntax : **CALibrate:VOLTage:GAIIn?<term>**

For example, the answer is: 1.000120<term>

10.10.3 Calibrate Gain Source Current

To calibrate the gain of the current programming:

Syntax : **CALibrate:CURrent:GAIIn<sp><NR2><term>**

With <NR2> = [0.900000 .. 1.100000]W

To read the calibration setting:

Syntax : **CALibrate:CURrent:GAIIn?<term>**

For example, the answer is: 1.000120<term>

10.10.4 Calibrate Offset Source Voltage

To calibrate the offset of the voltage programming:

Syntax : **CALibrate:VOLTage:OFFset<sp><NR2><term>**

With <NR2> = [-0.13 * Vmax .. 0.13 * Vmax]

To read the calibration setting:

Syntax : **CALibrate:VOLTage:OFFset?<term>**

For example, the answer is: -0.246000<term>

10.10.5 Calibrate Offset Source Current

To calibrate the offset of the current programming:

Syntax : **CALibrate:CURrent:OFFset<sp><NR2><term>**

With <NR2> = [-0.13 * Imax .. 0.13 * Imax]

To read the calibration setting:

Syntax : **CALibrate:CURrent:OFFset?<term>**

For example, the answer is: -0.246000<term>

10.10.6 Calibrate Gain Measure Voltage

To calibrate the gain of the voltage monitoring:

Syntax : **CALibrate:VOLTage:MEAsure:GAIIn<sp><NR2><term>**

With <NR2> = [0.900000 .. 1.100000]

To read the calibration setting:

Syntax : **CALibrate:VOLTage:MEAsure:GAIIn?<term>**

For example, the answer is: 1.000120<term>

10.10.7 Calibrate Gain Measure Current

To calibrate the gain of the current monitoring:

Syntax : **CALibrate:CURrent:MEAsure:GAIIn<sp><NR2><term>**

With <NR2> = [0.900000 .. 1.100000]

To read the calibration setting:

Syntax : **CALibrate:CURrent:MEAsure:GAIIn?<term>**

For example, the answer is: 1.000120<term>

10.10.8 Calibrate Offset Measure Voltage

To calibrate the offset of the voltage monitoring:

Syntax : **CALibrate:VOLTage:MEAsure:OFFset<sp><NR2><term>**

With <NR2> = [-0.13 * Vmax .. 0.13 * Vmax]

To read the calibration setting:

Syntax : **CALibrate:VOLtage:MEAsure:OFFset?<term>**

For example, the answer is: *-0.246000<term>*

10.10.9 Calibrate Offset Measure Current

To calibrate the offset of the current monitoring:

Syntax : **CALibrate:CURrent:MEAsure:OFFset<sp><NR2><term>** With <NR2> = [-0.13 * I_{max} .. 0.13 * I_{max}]

To read the calibration setting:

Syntax : **CALibrate:CURrent:MEAsure:OFFset?<term>**

For example, the answer is: *-0.246000<term>*

10.11 System Subsystem

10.11.1 Remote Shutdown (RSD)

To set the remote shutdown:

Syntax : **SYSTem:RSD:[STAtus]<sp><boolean><term>**

To read the last settings, send the query:

Syntax : **SYSTem:RSD:[STAtus]?<term>**

Results can be 0 or 1.

10.11.2 Voltage Limit

To set the limits of the voltage:

Syntax : **SYSTem:LIMits:VOLtage<sp><NR2><term>**

To read the last settings:

Syntax : **SYSTem:LIMits:VOLtage?<term>**

For example, the answer is: *16.5000<term>*

10.11.3 Current Limit

To set the limits of the voltage:

Syntax : **SYSTem:LIMits:CURrent< sp><NR2><term>**

To read the last settings:

Syntax : **SYSTem:LIMits:CURrent?<term>**

For example, the answer is: *11.0000<term>*

10.11.4 Interface IP-Address

To set the address of the fieldbus:

Syntax : **SYSTem:INTerface:ANYbus:SETTING<sp>1,ADDRESS,<IP><term>**

To read the last settings:

Syntax : **SYSTem:INTerface:ANYbus:SETTING<sp>1,ADDRESS?<term>**

For example, the answer is: *010.001.000.137<term>*

10.11.5 Interface Netmask

To set the netmask of the fieldbus:

Syntax : **SYSTem:INTerface:ANYbus:SETTING<sp>1,NETMASK,<IP><term>**

To read the last settings:

Syntax : **SYSTem:INTerface:ANYbus:SETTING<sp>1,NETMASK?<term>**

For example, the answer is: *255.255.254.000<term>*

10.11.6 Interface Gateway

To set the gateway of the fieldbus:

Syntax : **SYSTem:INTerface:ANYbus:SETTING<sp>1,GATEWAY,<IP><term>**

To read the last settings:

Syntax : **SYSTem:INTerface:ANYbus:SETTING<sp>1,GATEWAY?<term>**

For example, the answer is: *000.000.000.000<term>*

10.11.7 Interface DHCP

To set DHCP of the fieldbus:

Syntax : **SYSTem:INTerface:ANYbus:SETTING<sp>1,DHCP,<boolean><term>**

To read the last settings:

Syntax : **SYSTem:INTerface:ANYbus:SETTING<sp>1,DHCP?<term>**

For example, the answer is: *0<term>*

10.11.8 Interface Node Address

To set the node-address of the serial-based fieldbus:

Syntax : **SYSTem:INTerface:ANYbus:SETTING<sp>1,NODE,<NR1><term>**

To read the last settings:

Syntax : **SYSTem:INTerface:ANYbus:SETTING<sp>1,NODE?<term>**

For example, the answer is: *000<term>*

10.11.9 Interface Baud Rate

To set the baud rate of the serial-based fieldbus:

Syntax : **SYSTem:INTerface:ANYbus:SETTING<sp>1,BAUDRATE,<NR1><term>**

To read the last settings:

Syntax : **SYSTem:INTerface:ANYbus:SETTING<sp>1,BAUDRATE?<term>**

For example, the answer is: *7<term>*

10.11.10 Interface Data Format

To set the parameter data format:

Syntax : **SYSTem:INTerface:ANYbus:SETTING<sp>1,DATAFORMAT,<boolean><term>**

To read the last settings:

Syntax : **SYSTem:INTerface:ANYbus:SETTING<sp>1,DATAFORMAT?<term>**

For example, if the data format is 16-bit format: 1<term>

10.11.11 Interface Apply

To apply new interface settings:

Syntax : **SYSTem:INTerface:ANYbus:SETTING<sp>1,APPLY<term>**

10.11.12 Interface Type

To request what interface is inserted in the PSC-ANY-EXT

Syntax : **SYSTem:INTerface:ANYbus:STAtus<sp>1,TYPE?<term>**

For example, the answer is: CANopen<term>

10.11.13 Error

If an unknown command, an invalid value or an illegal setting is received by the PSC-ANY-EXT, an error is generated. An error message is stored in the FIFO error queue, which contains the error number and a description of the kind of error. The error queue can contain a maximum of 100 errors; more error messages are ignored. The command to read the queue, 1 error at a time:

Syntax : **SYSTem:ERRor?<term>**

The PSC-ANY-EXT returns 1 error from the FIFO list and clears it from the queue. If there are no errors (so the queue is empty), the result of this query will be : '0,None'. So, after 100 readings of 'SYSTem:ERRor?', the queue is empty for sure. After the *CLS command, the queue is empty as well.

10.11.14 Password

To protect the most essential settings of the system (calibration values, *PUD, password) a password can be used.

The default password is : "DEPOWER". To apply a password, send the command:

Syntax : **SYSTem:PASsword<sp><old_password>,<new_password><term>**

If no password is used, <old_password> must be "DEFAULT" (case insensitive) and <new_password> the password to be used.

To remove the password, <old_password> must be the current password and <new_password> must be "DEFAULT" (case insensitive).

Maximum length of password is 9 characters.

Be aware

When a password is unknown or forgotten, the console can be used to return to factory default settings. This will restore the factory default password. The network and calibration settings will also be set to factory default. See chapter 6 for more details.

To store the new password, refer to chapter 10.7 (*SAV)

To read if a password is used, send the query

Syntax : **SYSTem:PASsword:STAtus?<term>**

If no password is used, the PSC-ANY-EXT will return 0, otherwise it returns 1.

10.11.15 Console

To switch from the SCPI-terminal to the console:

Syntax : **SYSTem:COMMunicate:CONsole<term>**

10.11.16 Ctrlmux

To switch between SCPI- or fieldbus-based control over the power supply:

Syntax : **SYSTem:COMMunicate:CTRImux<sp><NR1><term>**

with NR1=0,1 (Fieldbus, SCPI respectively)

To read the last value:

Syntax : **SYSTem:COMMunicate:CTRImux?<term>**

For example, the answer is: 1

10.11.17 Baud Rate

To set the SCPI-terminal baud rate:

Syntax : **SYSTem:COMMunicate:BAUd**<sp><NR1><term>

<NR1>	1	2	3	4	5	6	7	8
Baud Rate	9600	19200	38400	57600	115200	230400	460800	921600

10.11.18 Terminator

The terminator can be chosen for the communication. The terminator is however set to default on a power-on event 9ASCII character 0AH, 10d)

To set the Terminator:

Syntax : **SYSTem:COMMunicate:TERminator**<sp><value><term>

with <value> = CR, CRLF or LF

LF = Linefeed = 0AH = 10d

CR = Carriage Return = 0DH = 13d

To read the last value:

Syntax : **SYSTem:COMMunicate:TERminator?**<term>

10.11.19 Register Structure

The PSC-ANY-EXT provides two register structures which contain actual Power Supply status information.

To read the registers:

Syntax : **STATus:REGister:A?**<term>

Syntax : **STATus:REGister:B?**<term>

The PSC-ANY-EXT will return a decimal number which represents the binary status of the status signals. For example, if the power supply is in CC-mode and signals DC-Fail, the register A condition will be:

66<term> (= 2 + 64). See the "Fieldbus Implementation Guide" on www.DeltaPowerSupplies.com by navigating to "Products > Interfaces > Anybus unit (external) > Manuals". for an overview of the registers.

10.11.20 S*CLS

This reset command clears the error queue. See chapter 0 for details.

Syntax: ***CLS**<term>

11 SCPI-Command List

*IDN?<term>	22
*PUD<sp><data><term>	22
*PUD?<term>	22
*SAV<term>	22
*SAV<sp><password><term>	22
*RST<term>	23
*RCL<term>	23
*OPC<term>	23
SOURce:VOLtage<sp><NR2><term>	23
SOURce:VOLtage?<term>	23
SOURce:CURrent<sp><NR2><term>	23
SOURce:CURrent?<term>	23
SOURce:VOLtage:MAXimum< sp><NR2><term>	23
SOURce:VOLtage:MAXimum?<term>	23
SOURce:CURrent:MAXimum<sp><NR2><term>	23
SOURce:CURrent:MAXimum?<term>	23
SOURce:VOLtage:STEpSize?<term>	23
SOURce:CURrent:STEpSize?<term>	23
MEASure:VOLtage?<term>	24
MEASure:CURrent?<term>	24
CALibrate:VOLtage:GAIN<sp><NR2><term>	25
CALibrate:VOLtage:GAIN?<term>	25
CALibrate:CURrent:GAIN<sp><NR2><term>	25
CALibrate:CURrent:GAIN?<term>	25
CALibrate:VOLtage:OFFset<sp><NR2><term>	25
CALibrate:VOLtage:OFFset?<term>	25
CALibrate:CURrent:OFFset<sp><NR2><term>	25
CALibrate:CURrent:OFFset?<term>	25
CALibrate:VOLtage:MEASure:GAIN<sp><NR2><term>	25
CALibrate:VOLtage:MEASure:GAIN?<term>	25
CALibrate:CURrent:MEASure:GAIN<sp><NR2><term>	25
CALibrate:CURrent:MEASure:GAIN?<term>	25
CALibrate:VOLtage:MEASure:OFFset<sp><NR2><term>	25
CALibrate:VOLtage:MEASure:OFFset?<term>	26
CALibrate:CURrent:MEASure:OFFset<sp><NR2><term>	26
CALibrate:CURrent:MEASure:OFFset?<term>	26
SYSTem:RSD:[STAtus]<sp><boolean><term>	26
SYSTem:RSD:[STAtus]?<term>	26
SYSTem:LIMits:VOLtage<sp><NR2><term>	26
SYSTem:LIMits:VOLtage?<term>	26
SYSTem:LIMits:CURrent< sp><NR2><term>	26
SYSTem:LIMits:CURrent?<term>	26
SYSTem:INTerface:ANYbus:SETTING<sp>1,ADDRESS,<IP><term>	26
SYSTem:INTerface:ANYbus:SETTING<sp>1,ADDRESS?<term>	26
SYSTem:INTerface:ANYbus:SETTING<sp>1,NETMASK,<IP><term>	26

SYSTem:INTErface:ANYbus:SETTING<sp>1,NETMASK?<term>	26
SYSTem:INTErface:ANYbus:SETTING<sp>1,GATEWAY,<IP><term>	26
SYSTem:INTErface:ANYbus:SETTING<sp>1,GATEWAY?<term>	26
SYSTem:INTErface:ANYbus:SETTING<sp>1,DHCP,<boolean><term>	26
SYSTem:INTErface:ANYbus:SETTING<sp>1,DHCP?<term>	26
SYSTem:INTErface:ANYbus:SETTING<sp>1,NODE,<NR1><term>	26
SYSTem:INTErface:ANYbus:SETTING<sp>1,NODE?<term>	26
SYSTem:INTErface:ANYbus:SETTING<sp>1,BAUDRATE,<NR1><term>	26
SYSTem:INTErface:ANYbus:SETTING<sp>1,BAUDRATE?<term>	26
SYSTem:INTErface:ANYbus:SETTING<sp>1,DATAFORMAT,<boolean><term>	27
SYSTem:INTErface:ANYbus:SETTING<sp>1,DATAFORMAT?<term>	27
SYSTem:INTErface:ANYbus:SETTING<sp>1,APPLY<term>	27
SYSTem:INTErface:ANYbus:STAtus<sp>1,TYPE?<term>	27
SYSTem:ERRor?<term>	27
SYSTem:PASsword<sp><old_password>,<new_password><term>	27
SYSTem:PASsword:STAtus?<term>	27
SYSTem:COMmunicate:CONsole<term>	27
SYSTem:COMmunicate:CTRImux<sp><NR1><term>	27
SYSTem:COMmunicate:CTRImux?<term>	27
SYSTem:COMmunicate:BAUd<sp><NR1><term>	28
SYSTem:COMmunicate:TERminator<sp><value><term>	28
SYSTem:COMmunicate:TERminator?<term>	28
STATus:REGister:A?<term>	28
STATus:REGister:B?<term>	28
*CLS<term>	28



12 EU Declaration of Conformity – PSC-ANY-EXT



We

Delta Elektronika
Vissersdijk 4
4301 ND Zierikzee
The Netherlands

Declare under sole responsibility that the following Interface:

PSC-ANY-EXT

Meet the intent of Directives:

2014/30/EU Electromagnetic Compatibility (EMC)
2014/35/EU Low Voltage Directive (LVD)
2011/65/EU Reduction of Hazardous Substances (RoHS2)

Compliance was demonstrated to the following specification as listed in the official Journal of the European Union:

EN 61326-1:2013	EMC requirements for electrical equipment for measurement, control and laboratory use
EN 61010-1:2010/A1:2019/AC:2019-04	Safety requirements for electrical equipment for measurement, control and laboratory use
EN IEC 63000:2018	Assessment of electrical and electronic products with respect to RoHS

J. Koopman
Managing director,
Zierikzee, January 2026